

CLEONI
LIGHTING

ON

P O R T F O L I O

© Copyright 2025



CLEONI PORTFOLIO
2025

“RECOGNIZING THE NEED IS THE PRIMARY CONDITION FOR DESIGN.” CHARLES EAMES

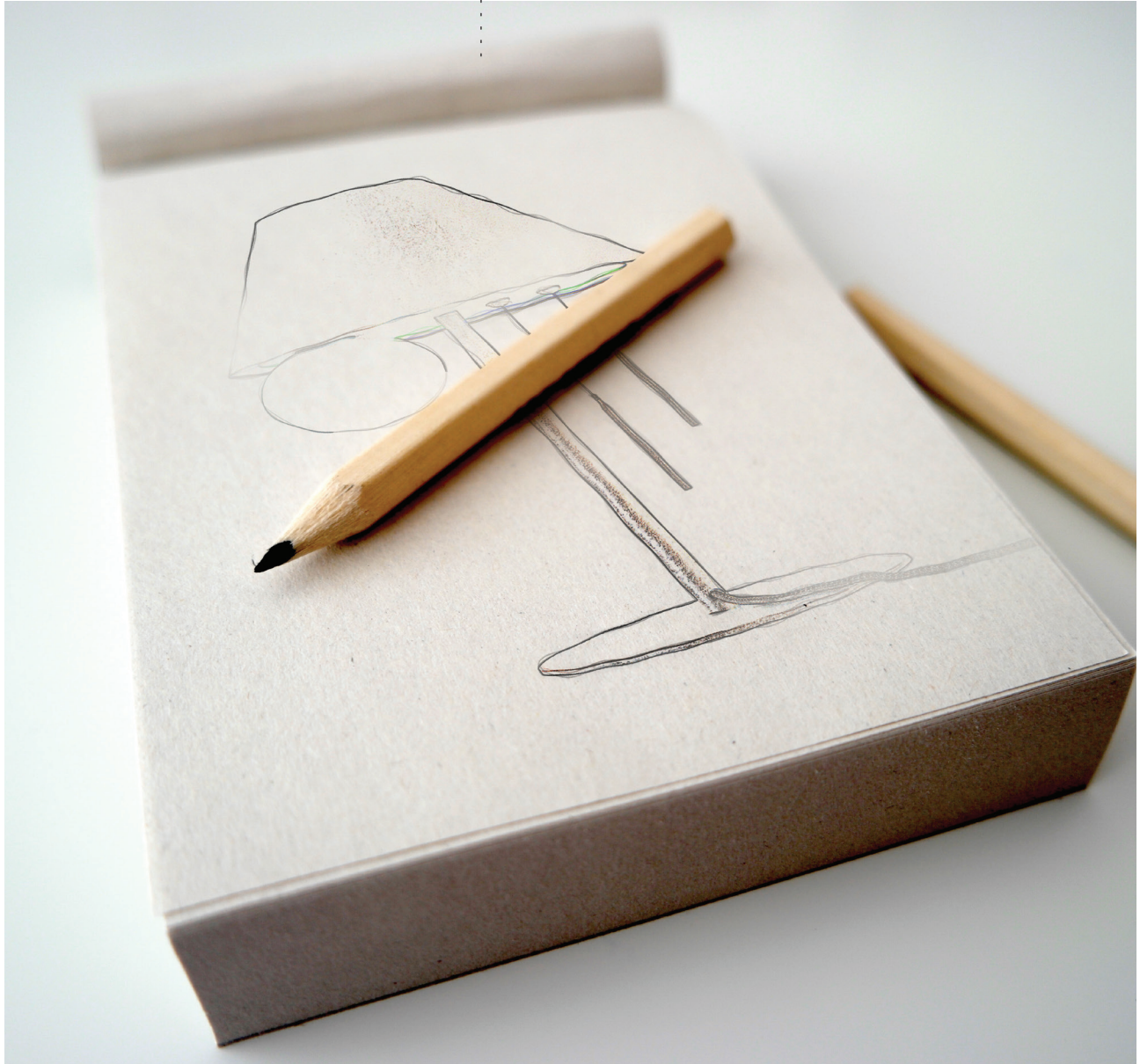

ŚWIAT CLEONI

Drogi Czytelniku,

W Cleoni wierzymy, że prawdziwy luksus tkwi w wolności wyboru. Nasze oprawy oświetleniowe nie są gotowymi produktami, lecz punktem wyjścia do stworzenia własnej, niepowtarzalnej interpretacji światła. Każdy kształt, każdy wymiar, każde wykończenie można dostosować tak, by odzwierciedlało Twoją wizję i współgrało z charakterem przestrzeni.

Od wielu lat, jako polska marka, łączymy rzemiosło z nowoczesną technologią, tworząc oświetlenie, które łączy funkcjonalność z ponadczasowym designem. Nasze oprawy nie tylko rozświetlają wnętrza - one je definiują, kreując atmosferę, dzięki której każda przestrzeń staje się naprawdę wyjątkowa.

Zaufaj naszemu doświadczeniu i wkrocz w świat Cleoni, gdzie światło staje się osobiste.

Z wyrazami szacunku,

CLEONI

INTRODUCTION

Dear Reader,

At Cleoni, we believe that true luxury lies in the freedom of choice. Our luminaires are not ready-made objects, but a starting point to create your own unique expression of light. Every shape, every dimension, every finish can be tailored to reflect your vision and harmonize with the character of your space.

For many years, as a Polish brand, we have combined craftsmanship with modern technology, delivering lighting that unites functionality with timeless design.

Our fixtures do more than illuminate interiors they define them, creating atmospheres that make each space truly one of a kind.

Trust our expertise and step into the world of Cleoni, where light becomes personal.

All the best.

CLEONI



10



11

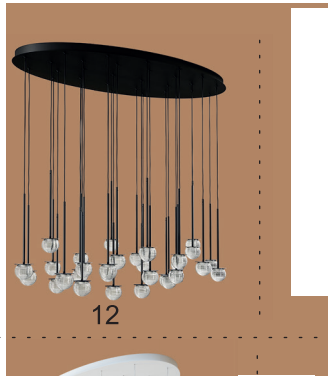

12



13



14

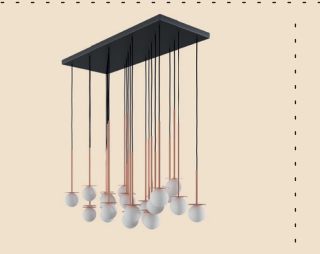

16

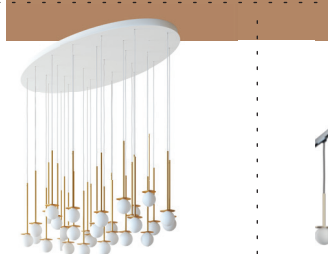

17



18

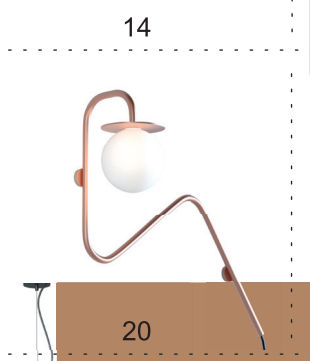

20

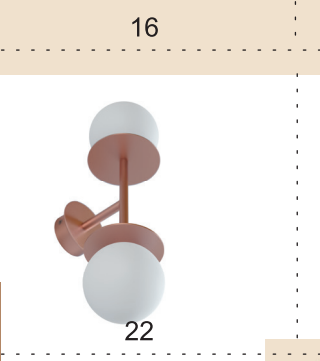

22

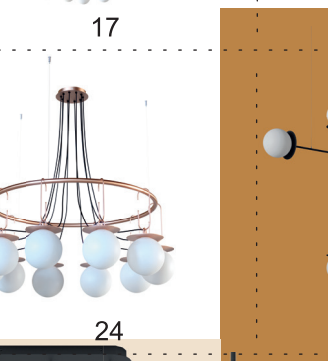

24

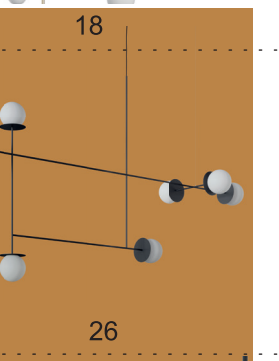

26

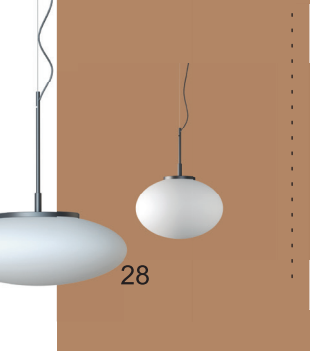

28

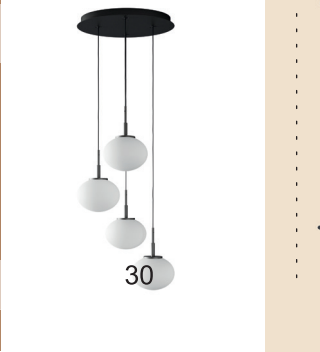

30

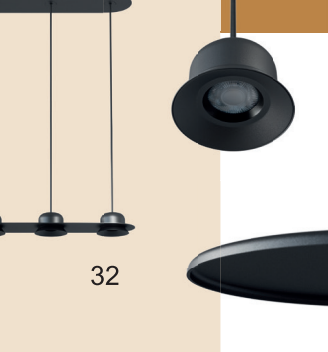

32



26

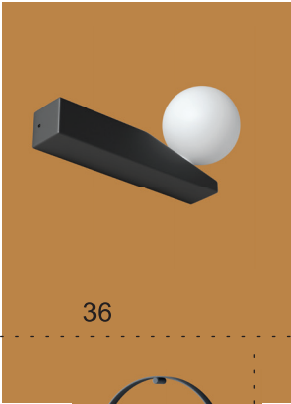

36



38

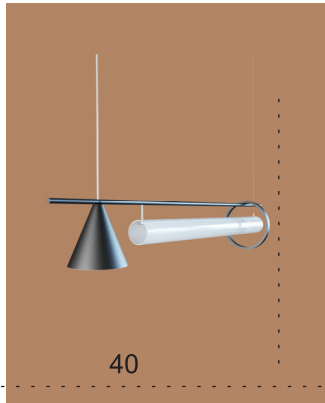

40



44

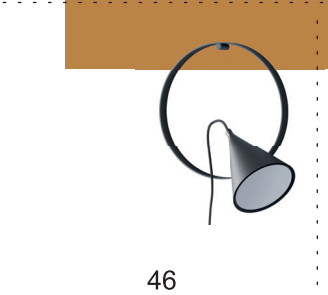

46



49



50

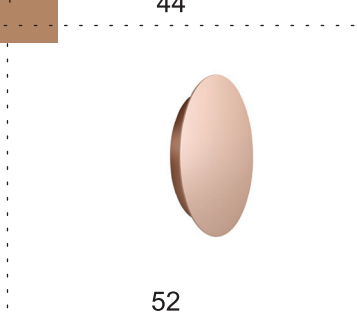

52

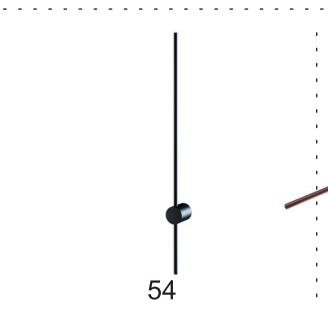

54

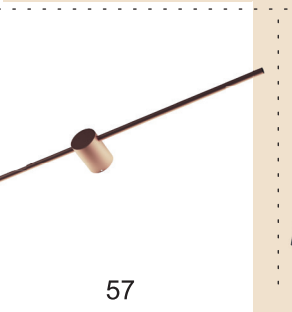

57

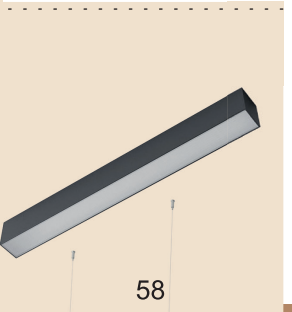

58

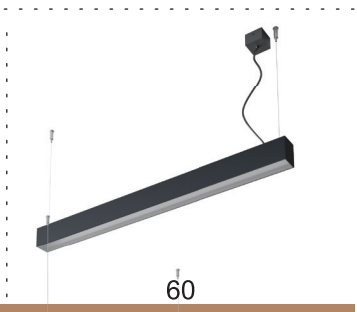

60

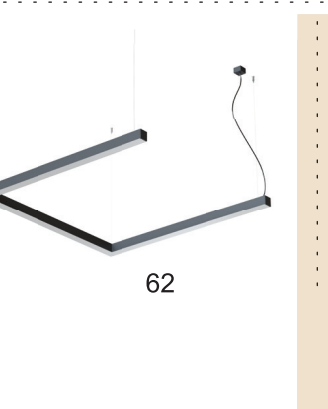

62

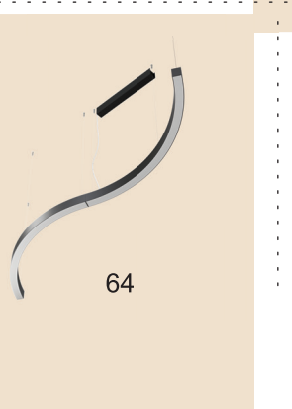

64

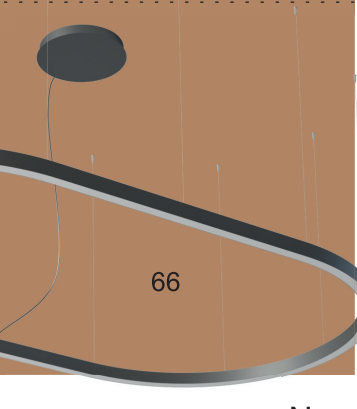

66

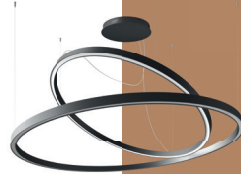
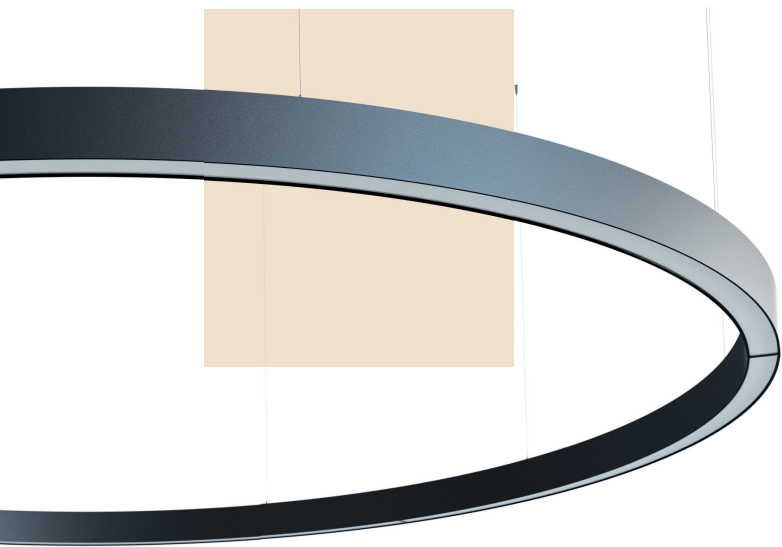

68



70



76



80

74



82



84



85



86



90



92

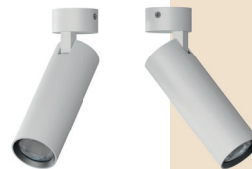

93



94

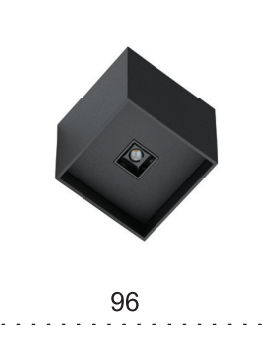

96

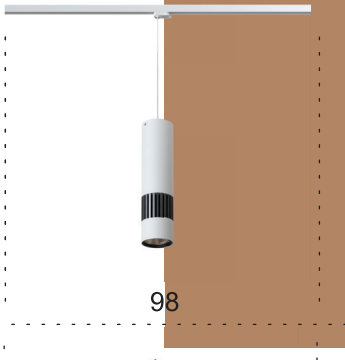

98

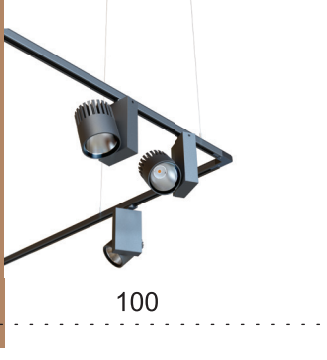

100



102

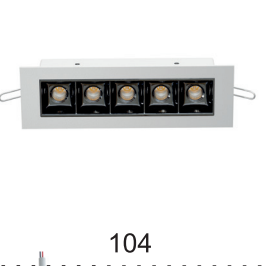

104

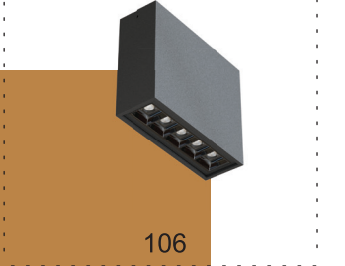

106



108



CLAR PENDING / LA362 /

PENDING LIGHT: CLAR

LIGHT SOURCE: LED

MATERIAL: STEEL, GLASS

NEW

MADE IN EU

CLEONI

200 - 500

Each ribbed glass lampshade is crafted in a Polish glassworks, where traditional craftsmanship meets modern technology. Thanks to precise workmanship and multi-stage quality control, every detail retains perfection, creating light of the highest class.

CLAR PENDING / LA362 / L

PENDING LIGHT: CLAR

LIGHT SOURCE: LED

MATERIAL: STEEL



NEW

MAXIMUM FLEXIBILITY.
DESIGN WITH
ENDLESS CONFIGURATIONS.



CLAR PANEL ELLIPSE PENDANT

PENDANT LUMINAIRE: CLAR PANEL ELLIPSE

LIGHT SOURCE: LED

MATERIAL: GLASS-Ø100 „HANDMADE”, STEEL

N^o 12

COTTON PENDANT/ RECESSED

LUMINAIRE: COTTON

LIGHT SOURCE: G9

MATERIAL: GLASS „HANDMADE”, STEEL

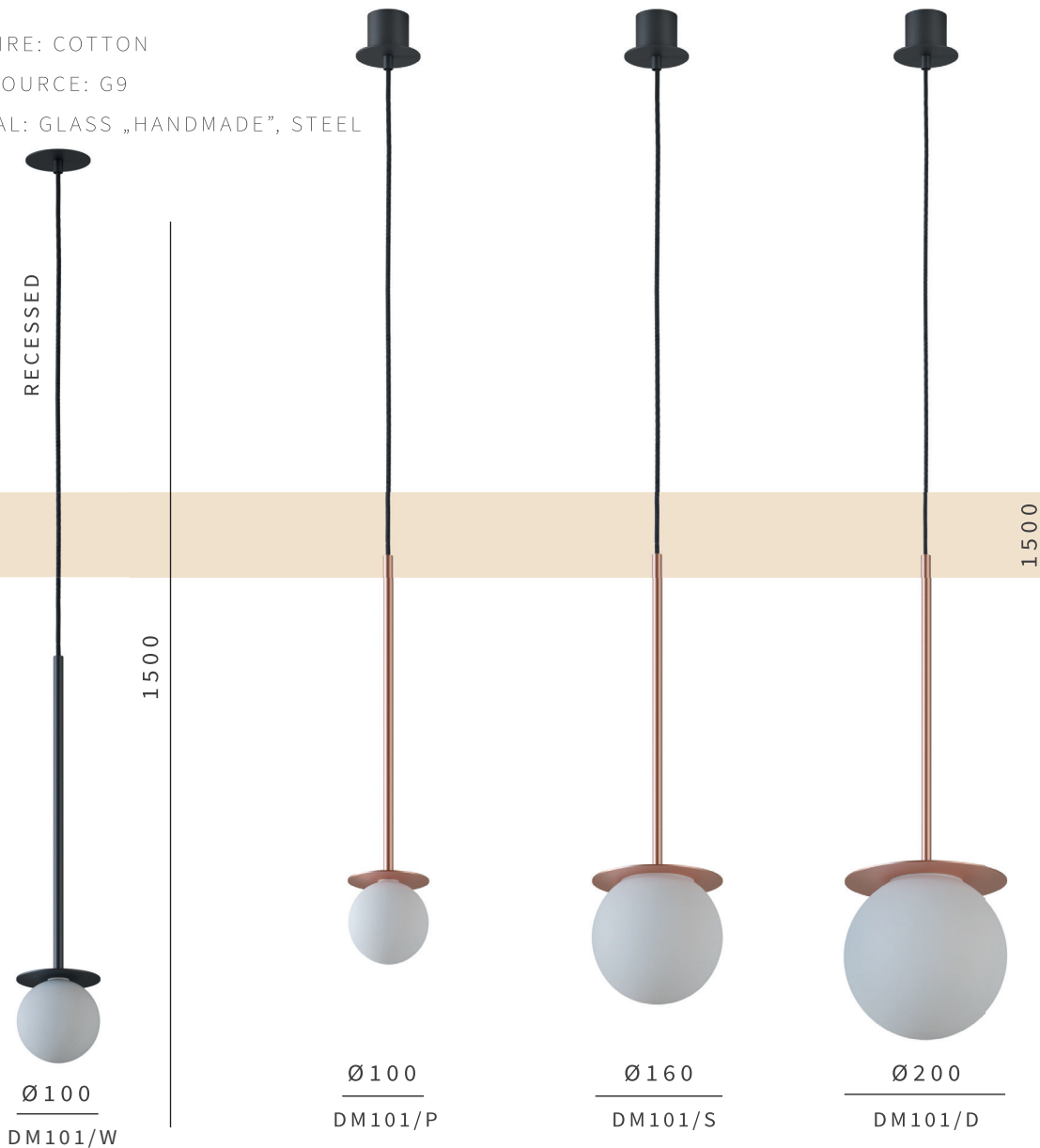

COTTON PANEL PENDANT/ DM101/LA211



MADE IN EU
CLEONI

SUPER YACHT CLUB Gdynia

PENDANT LUMINAIRE: COTTON PANEL
LIGHT SOURCE: G9/ LED
MATERIAL: GLASS-Ø100, Ø160, Ø200 „HANDMADE”, STEEL

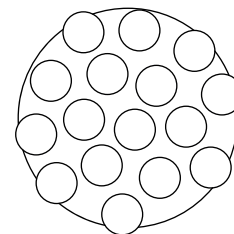

Ø 500

DM101/LA211/HF4

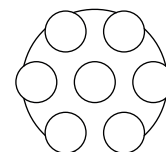

Ø 356

DM101/LA211/RH25

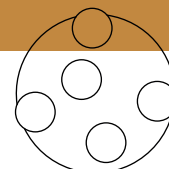

Ø 400

DM101/LA211/RH19

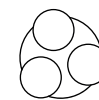

Ø 200

DM101/LA211/RH24



"INDIVIDUAL PROJECT"
EWELINA DRYGAŁA - DUSIŁO

PRIVATE INTERIOR

N^o 15



COTTON PANEL/ HF2
COTTON PANEL/ ET

MAXIMUM FLEXIBILITY.
DESIGN WITH
ENDLESS CONFIGURATIONS.

COTTON PANEL
HF3

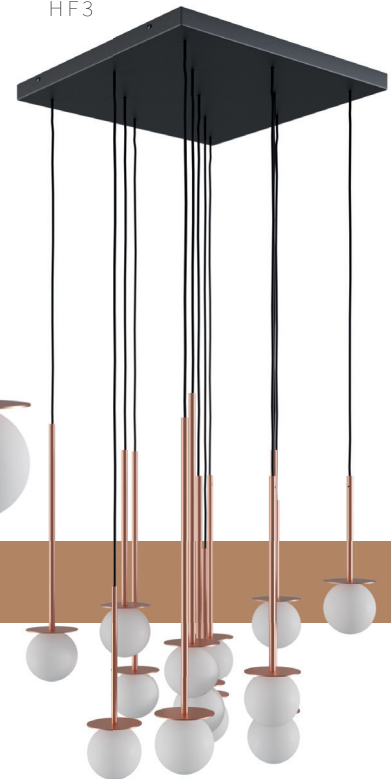

COTTON PANEL PENDANT/ DM101

PENDANT LUMINAIRE: COTTON PANEL

LIGHT SOURCE: G9/ LED

MATERIAL: GLASS-Ø100, Ø160, Ø200 „HANDMADE”, STEEL



COTTON PANEL

INTERIOR DESIGN
GRUPA MO
"WŁOSZKA" RESTAURANT,
POZNAŃ POLAND

N. 17

COTTON TRACK

NEW

PENDANT LUMINAIRE: COTTON TRACK

LIGHT SOURCE: G9

MATERIAL: GLASS-Ø100, Ø1



COTTON TRACK

NEW

PENDANT LUMINAIRE: COTTON TRACK

LIGHT SOURCE: G9

MATERIAL: GLASS-Ø100, Ø160

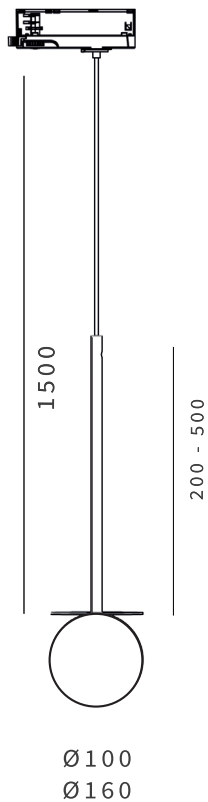

COTTON WALL LIGHT/ DM101

WALL LIGHT: COTTON

LIGHT SOURCE: G9

MATERIAL: GLASS-Ø100 „HANDMADE”, STEEL

LEFT VERSION -
DM101/LA42/A1/L

RIGHT VERSION -
DM101/LA42/A1/P

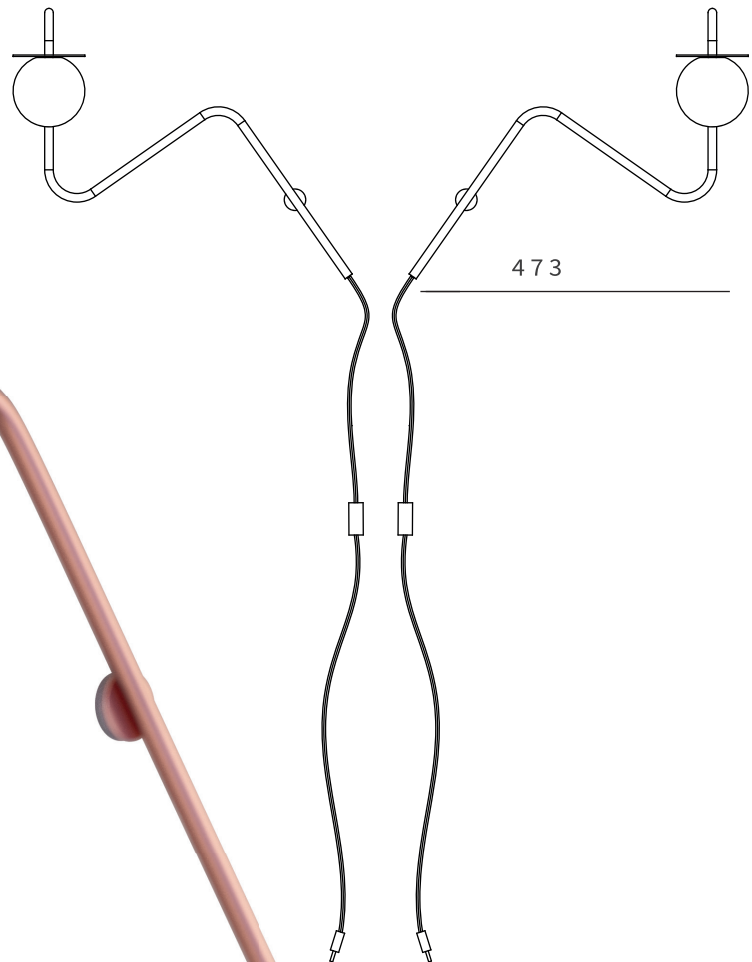
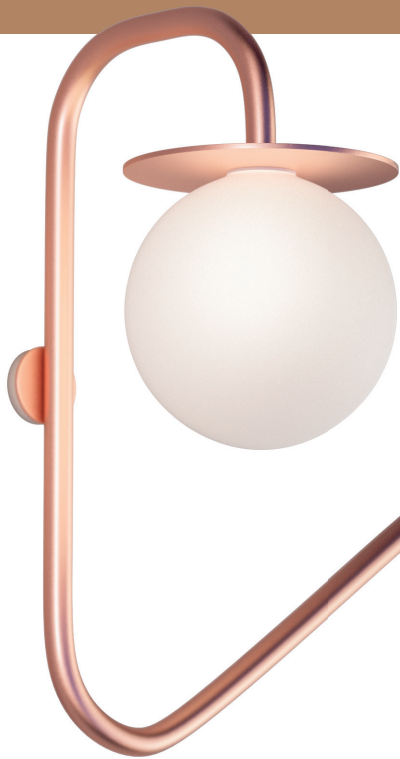

377

473

2000

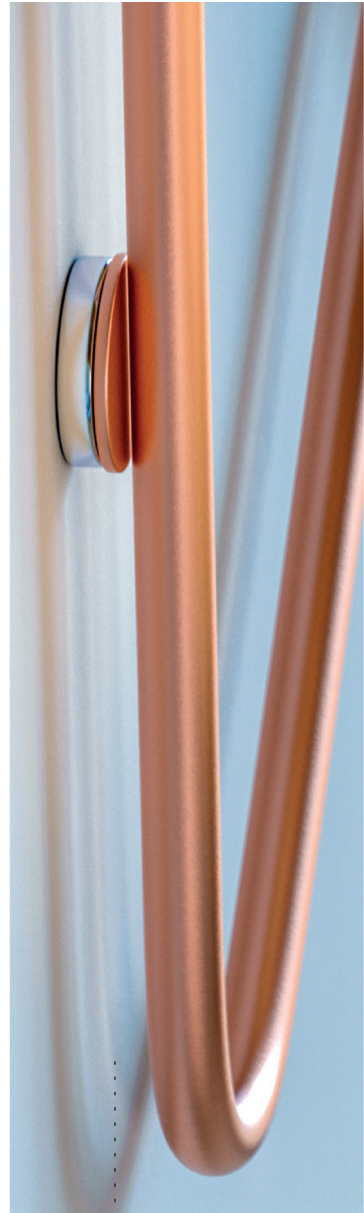

MADE IN EU
CLEONI

“DESIGN IS A PLAN FOR ARRANGING ELEMENTS IN SUCH A WAY AS BEST TO ACCOMPLISH A PARTICULAR PURPOSE.”

CHARLES EAMES

COTTON WALL/ TC1, TC2, TC3

WALL LIGHT: COTTON

MATERIAL AND LIGHT SOURCE:

GLASS - Ø100 - G9

GLASS - Ø160 - G9

GLASS - Ø200 - E27

„HANDMADE”, STEEL

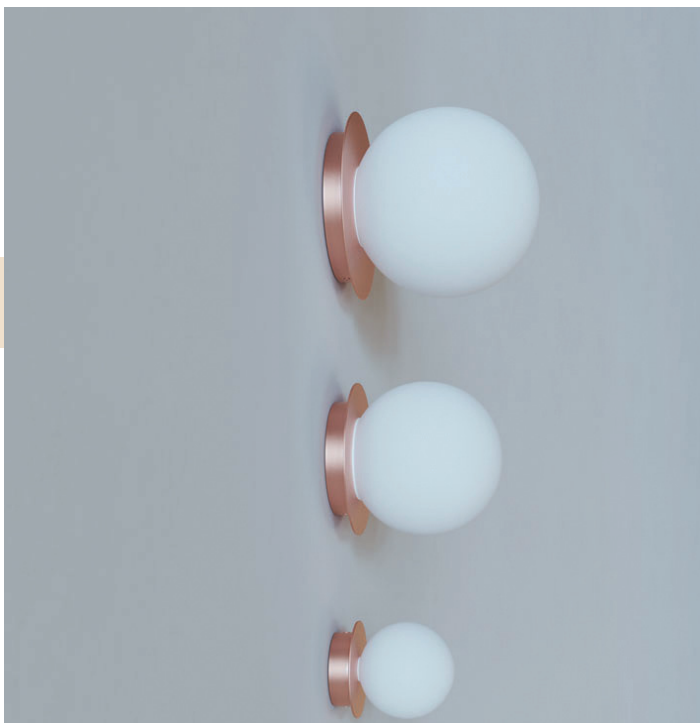

MI Projekty Wnętrz Katarzyna Kacik

COTTON WALL LIGHT/ DM101

WALL LIGHT: COTTON

LIGHT SOURCE: G9

MATERIAL: GLASS-Ø100 „HANDMADE”, STEEL



“INDIVIDUAL PROJECT”
BOHE ARCHITEKTURA
ANNA SKOWROŃSKA

PHOTO BY:
ANNA MASŁOWSKA





CORONA PENDANT / DM102

PENDANT LUMINAIRE: CORONA

LIGHT SOURCE: E27

MATERIAL: GLASS-Ø200 „HANDMADE”, STEEL

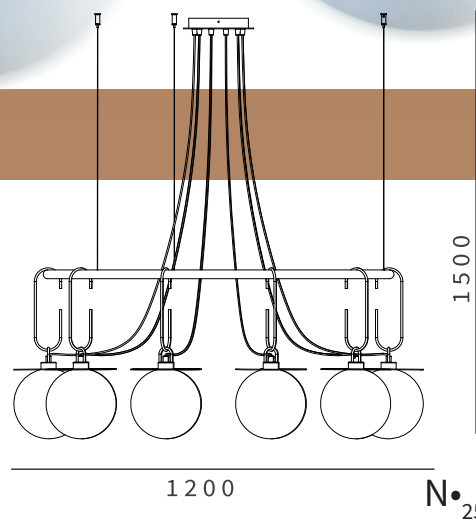

VARIANT PENDANT

PENDANT LUMINAIRE: VARIANT

LIGHT SOURCE: 7 X E27

MATERIAL: STEEL,

GLASS-Ø200 „HANDMADE

MADE IN EU
CLEONI

2783

MAXIMUM FLEXIBILITY.

DESIGN WITH
ENDLESS CONFIGURATIONS.

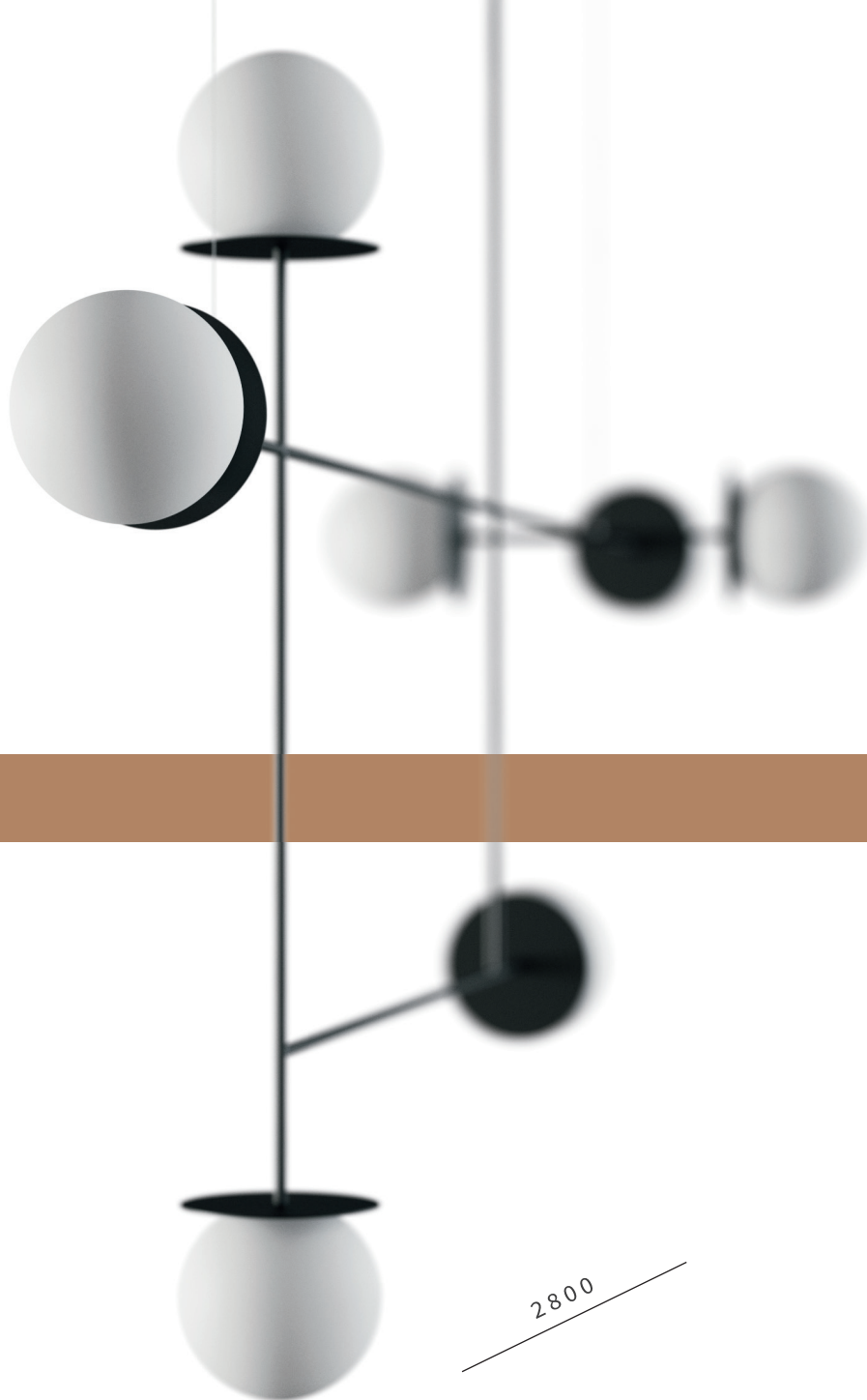

SUPER YACHTS CLUB - GDYNIA



SUPER YACHT CLUB · GDYNIA

OVO PENDANT / DM145

PENDANT LUMINAIRE: OVO

LIGHT SOURCE: E27

MATERIAL: GLASS „HANDMADE”

STEEL

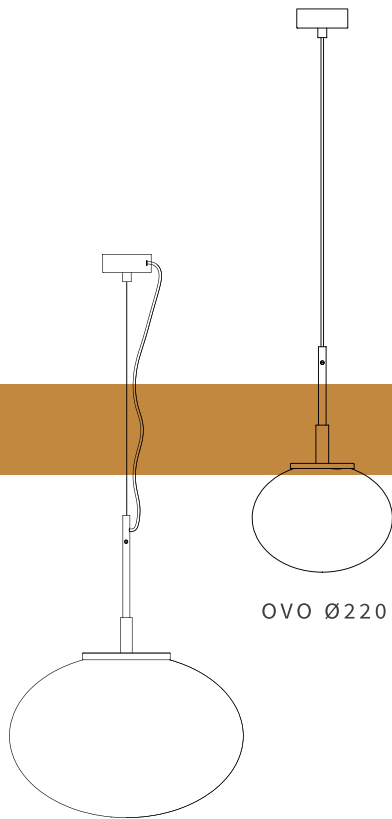

OVO Ø220

OVO Ø400

MADE IN EU
CLEONI



“DESIGN REVEALS WHAT
ART CONCEALS.” MARLENE PROTEAU



OVAL PENDANT/ LA15/A1

PENDANT LUMINAIRE: OVAL

LIGHT SOURCE: E27

MATERIAL: GLASS „HANDMADE” STEEL



550



MADE IN EU
CLEONI

“DESIGN IS THE PURPOSE OF ELEMENTS LIKE
COMPOSITION, PROPORTION AND BALANCE.” PEPPER HUME

OVO PANEL ELLIPSE PENDANT / DM145/LA14/TR2

PENDANT LUMINAIRE: OVO PANEL ELLIPSE

LIGHT SOURCE: E27

MATERIAL: GLASS-Ø220 „HANDMADE”, STEEL





*Dominika
Duzner - Huzh*

OTI A2 PENDANT/LA361/A2/

PENDANT LUMINAIRE: OTI A2

LIGHT SOURCE: LED

MATERIAL: GLASS, „HANDMADE”, STEEL



Ø226

OTI A4 PENDANT/LA361/A4

PENDANT LUMINAIRE: OTI PENDANT

LIGHT SOURCE: LED

MATERIAL: STEEL



OTI A3 PENDANT/LA361/A3

PENDANT LUMINAIRE: OTI PENDANT

LIGHT SOURCE: LED

MATERIAL: STEEL



OTI A1 PENDANT/LA361/A3

PENDANT LUMINAIRE: OTI PENDANT

LIGHT SOURCE: LED

MATERIAL: STEEL

MADE IN EU
CLEONI



“KVARC” · DESIGN BY
ŁUKASZ WAWRZYŃIAK

KVARC WALL LIGHT/ LA173



PROJECT : INTERIOR DESIGN STUDIO
IZABELA KRZEMIEŃ : PRO KONCEPT

Ø100

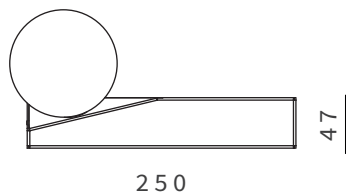

LEFT VERSION/ LA173/A2

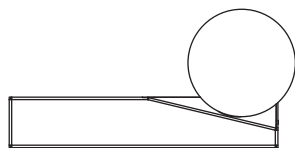

RIGHT VERSION/ LA173/A1



WALL LIGHT: KVARC

LIGHT SOURCE: G9

MATERIAL: GLASS „HANDMADE”, STEEL

DUO PENDANT / DM104

PENDANT LUMINAIRE: DUO

LIGHT SOURCE: 2XG9; 2X PROJECTOR LED* SLM L09

MATERIAL: GLASS-Ø160 | Ø200 „HANDMADE“, STEEL, ALUMINIUM

*LED PHILIPS



MAXIMUM FLEXIBILITY.

DESIGN WITH
ENDLESS CONFIGURATIONS.



MADE IN EU
CLEONI

INTERIOR DESIGN · KANCELARIA
MGR INŻ. ARCH. MAGDALENA · NOTARIALNA
KOPCZYŃSKA · POLAND, OBORNIKI WLKP

MADE IN EU
CLEONI



“INVIDIA” · DESIGN BY
ŁUKASZ WAWRZYNIAK

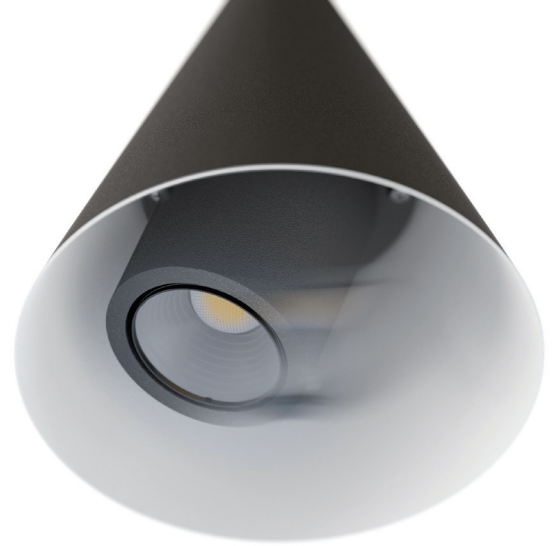

INVIDIA PENDANT/ LA217/A1/L13

PENDANT LUMINAIRE: INVIDIA

LIGHT SOURCE: LED

MATERIAL: STEEL, ALUMINIUM, PLEXI

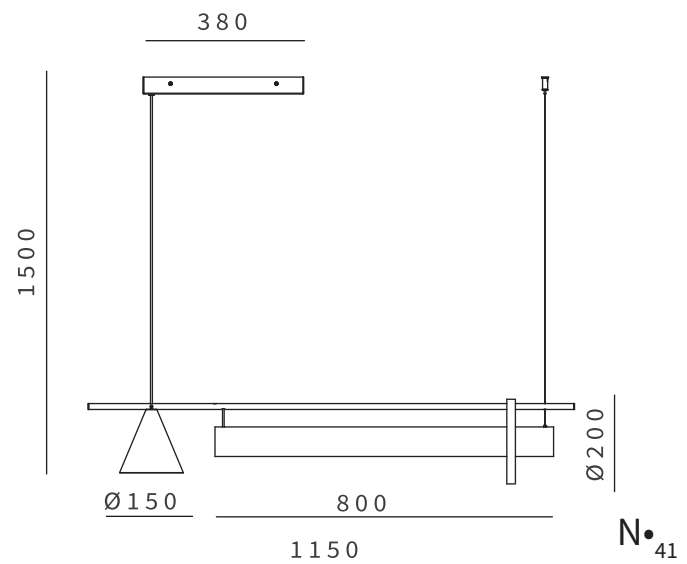



NATALIA WIETESKA

RIM COLLECTION

“Rim is a collection of lamps inspired by simple and graphical design. The hoop, or “rim”, is a single element that forms a bold, clean line. The design manifesto being; to create products whose functions result from the form, keeping it minimal and unfussy.

The Rim collection consists of a wall lamp, the assembly of which does not require preparing electrical cables in the wall - it is simply hung and powered from the sockets. The pendant lamp, which due to its metal tube system, allows for a quick and easy height adjustments. There is also a desk lamp, in which the cable, if it is too long, can be wrapped around the vertical arm.”

.....

PILL COLLECTION

“The Pill lamp collection are harmonious in shape and proportion. Their simplicity and adaptability means they can be placed in very different interiors, and used in mixed groups or singularly.

The wall lamp creates a typical graphic character - with few constituent parts. The cabling solution, running through the central tube, is an aesthetically interesting feature that is deliberately exposed to enforce the reductive quality of the design. The hanging luminaire is a symmetrical composition of two ‘tablets’ - one for illumination, with a glass shade, the other - a contrasting solid metal element. The lamp has a timeless look, but is also a powerful light source, so it can be used over a table, island or bar.”

*Natalia
Wieteske*

RIM PENDANT / LA39C1

PENDANT LUMINAIRE: RIM

LIGHT SOURCE: 2X LED

MATERIAL: STEEL

MADE IN EU

CLEONI

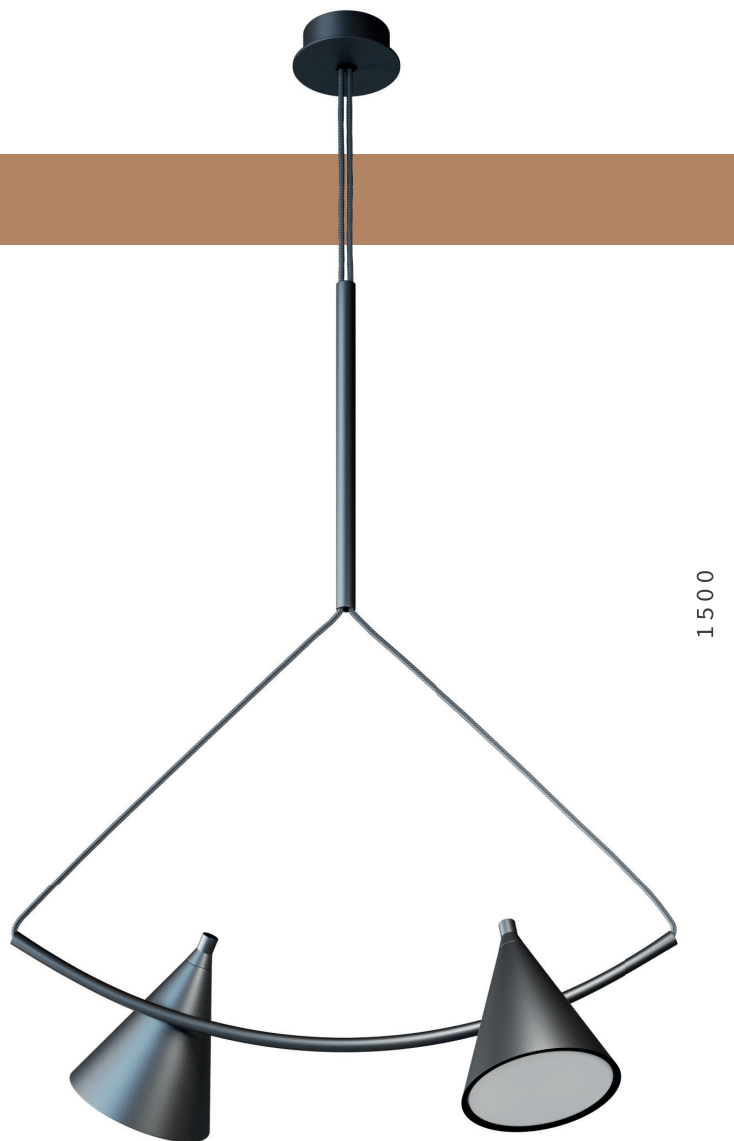



Drewmax

"RIM" DESIGN BY
NATALIA WIETESKA

MADE IN EU
CLEONI



“RIM” DESIGN BY
NATALIA WIETESKA

N•
46

RIM WALL LIGHT/ LA39A

WALL LIGHT: RIM
LIGHT SOURCE: LED
MATERIAL: STEEL

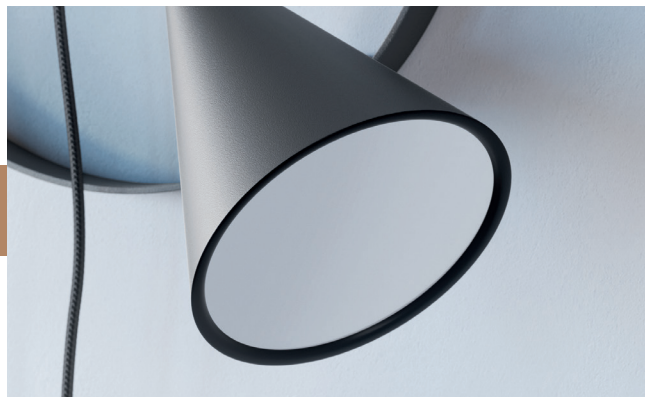
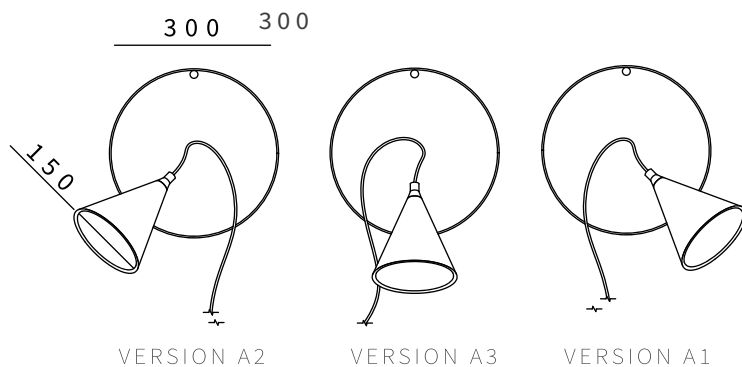

RIM PENDANT / LA39 / F1

TABLE LIGHT: RIM
LIGHT SOURCE: LED
MATERIAL: STEEL

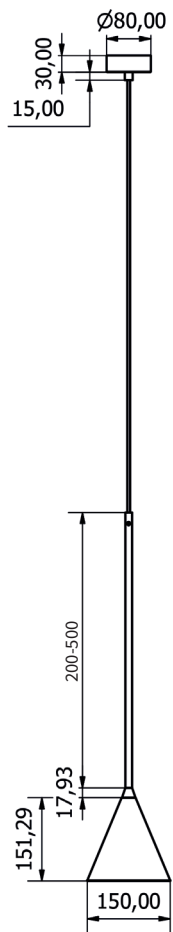

RIM TABLE LIGHT/ LA39B1

TABLE LIGHT: RIM
LIGHT SOURCE: LED
MATERIAL: STEEL



470

152

PILL PENDANT/ LA19A1

PENDANT LUMINAIRE: PILL

LIGHT SOURCE: LED

MATERIAL: GLASS „HANDMADE”, STEEL

MADE IN EU
CLEONI

1500

Ø 176

N[•]₅₀

LAKARI WALL LIGHT/ LA186

WALL LIGHT: LAKARI
LIGHT SOURCE: LED
MATERIAL: ALUMINIUM



Ø150- Ø600

MADE IN EU
CLEONI



RESTAURANT INTERIOR · CRACOW,
"BOTTIGLIERIA 1881" · POLAND



CRACOW,
POLAND

RESTAURANT
INTERIOR
"BOTTIGLIERIA
1881"

INTERIOR DESIGN
MGR INŻ. ARCH.
MAGDALENA KOPCZYŃSKA

KANCELARIA
NOTARIALNA
POLAND,
OBORNIKI WLKP



LINE WALL LIGHT / P001/LA412/K

WALL LIGHT: LINE
LIGHT SOURCE: LED
MATERIAL: STEEL



INTERIOR DESIGN
MGR INŻ. ARCH.
MAGDALENA KOPCZYŃSKA

KANCELARIA
NOTARIALNA
POLAND,
OBORNIKI WLKP



LINE B WALL LIGHT / P001/LA412/B1

WALL LIGHT: LINE B

LIGHT SOURCE: LED

MATERIAL: STEEL

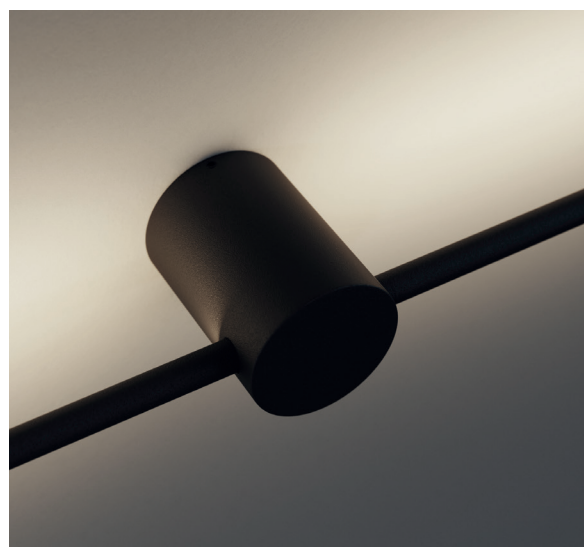
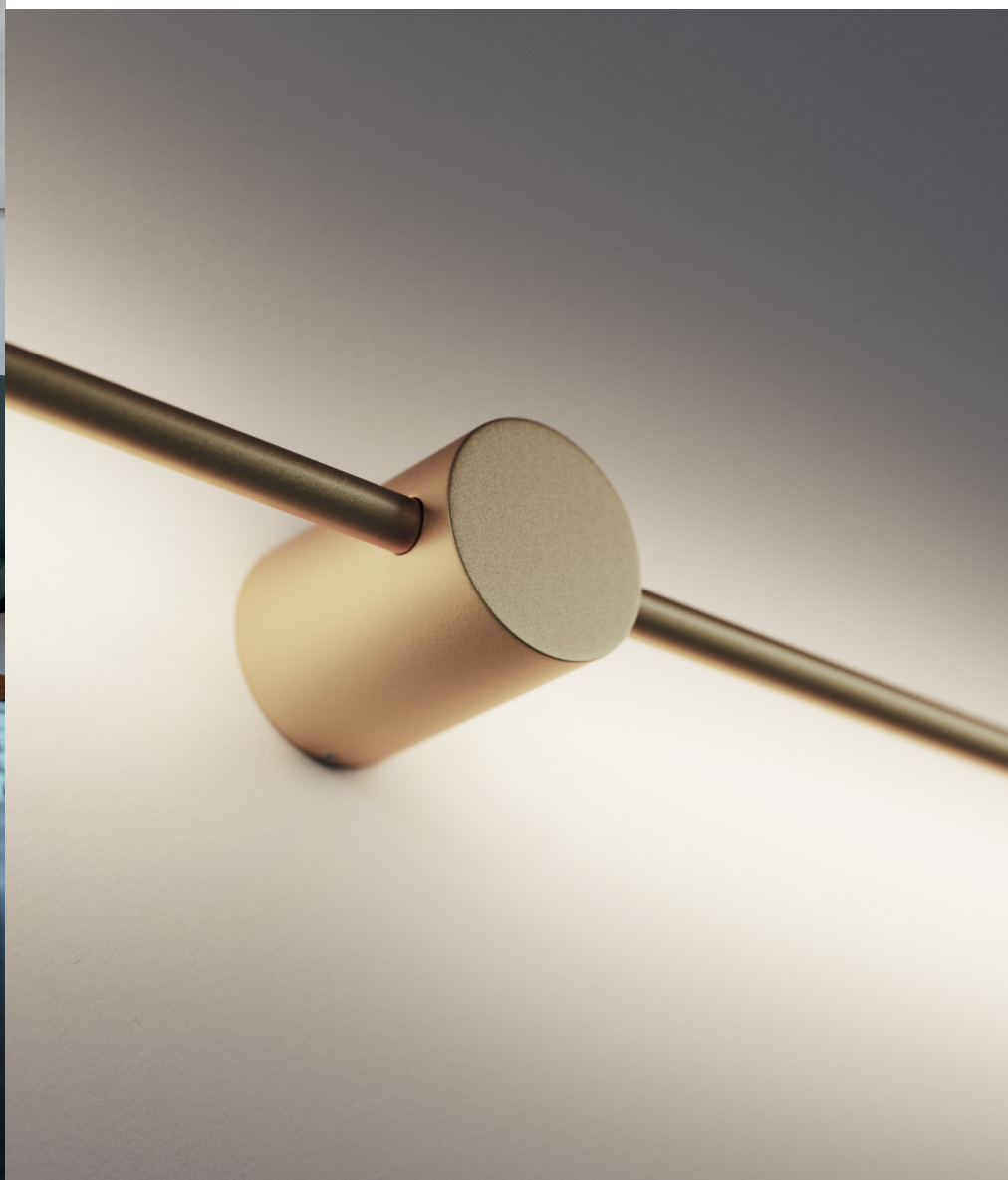

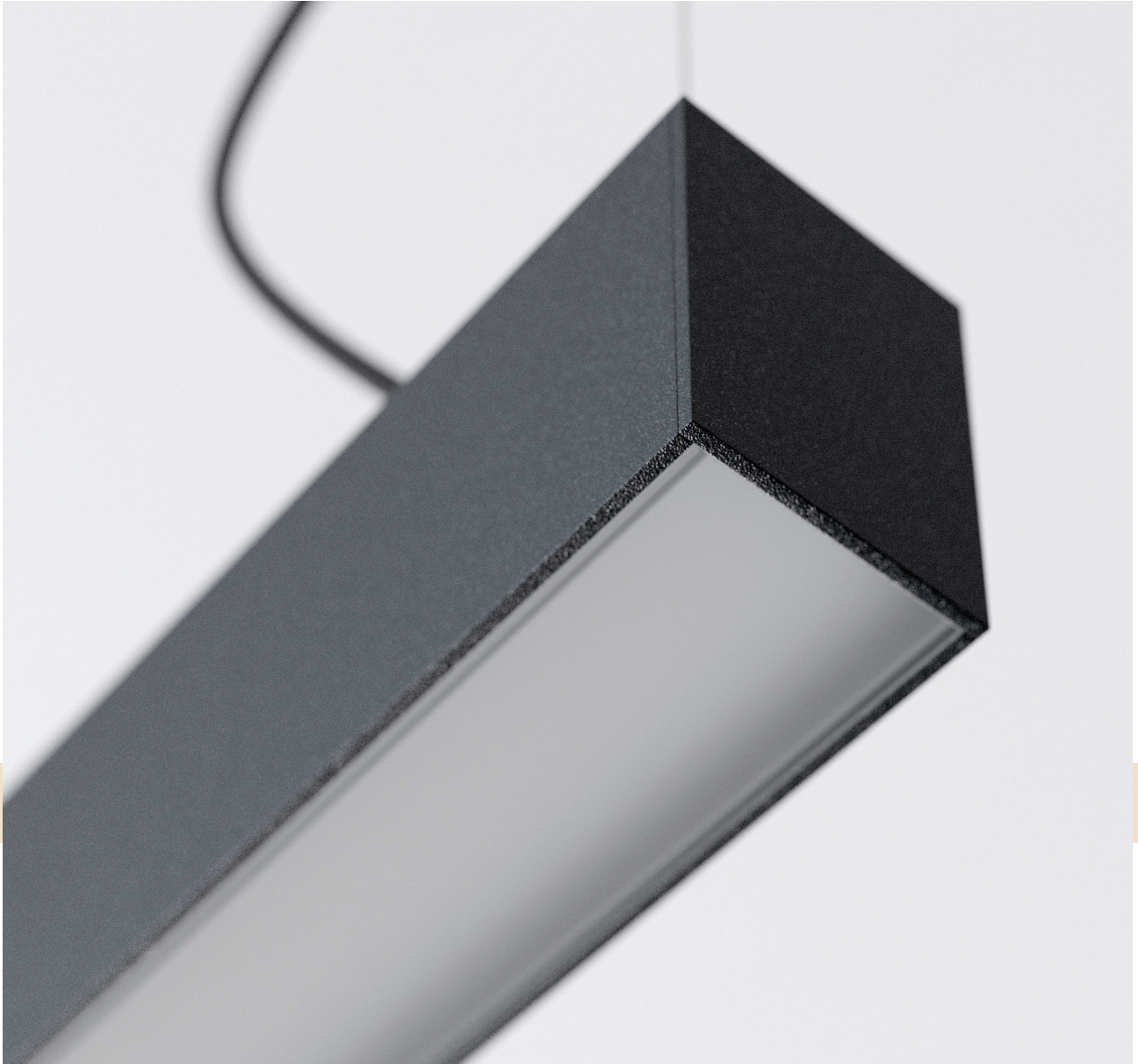

MADE IN EU
CLEONI

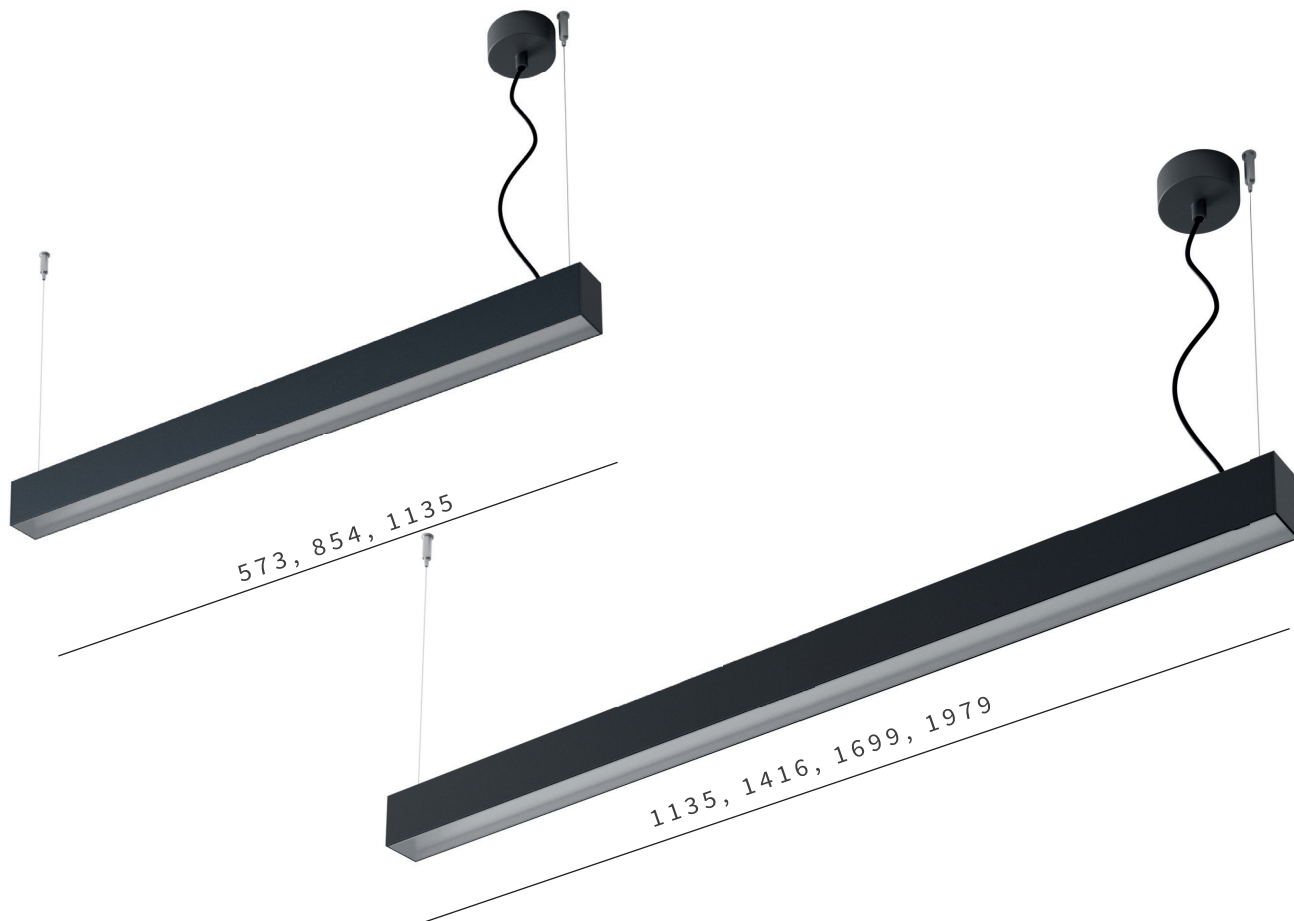

CLEOLINE - 1 PENDANT/SL105

PENDANT LUMINAIRE: CLEOLINE-1

LIGHT SOURCE: LED*

MATERIAL: ALUMINIUM



*LED PHILIPS

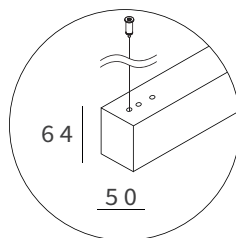



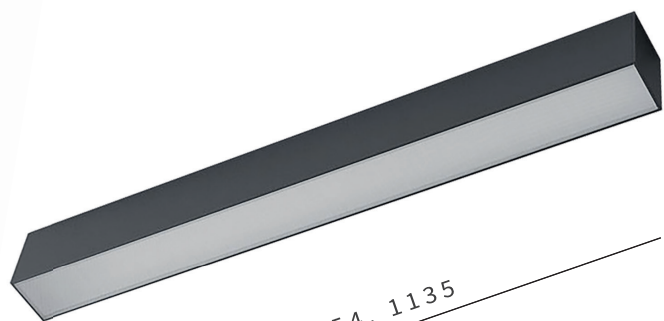

373, 854, 1135

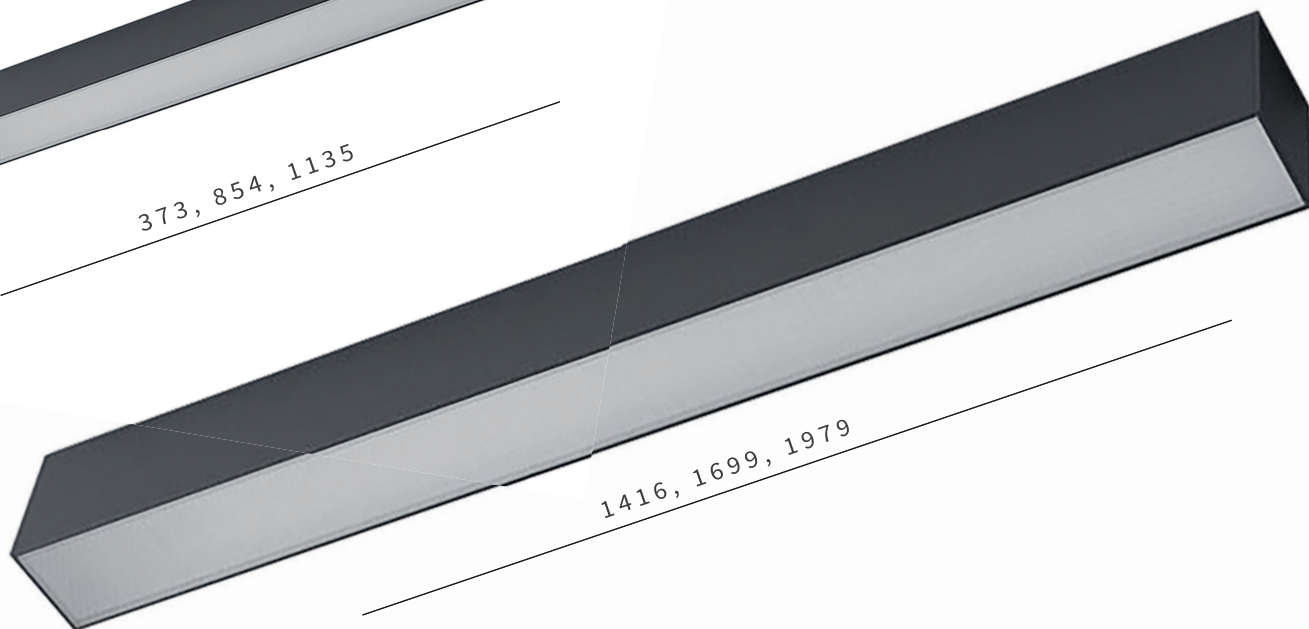

1416, 1699, 1979

CLEOLINE - 1 CEILING /SL105/LA448

CEILING LUMINAIRE: CLEOLINE-1

LIGHT SOURCE: LED*

MATERIAL: ALUMINIUM



*LED PHILIPS

CLEOLINE-S PENDANT / SL105

PENDANT LUMINAIRE: CLEOLINE-S

LIGHT SOURCE: LED*

MATERIAL: ALUMINIUM



*LED PHILIPS



MADE IN EU
CLEONI

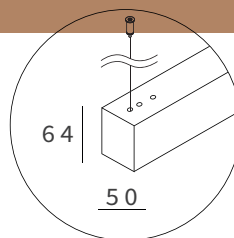

N° 62

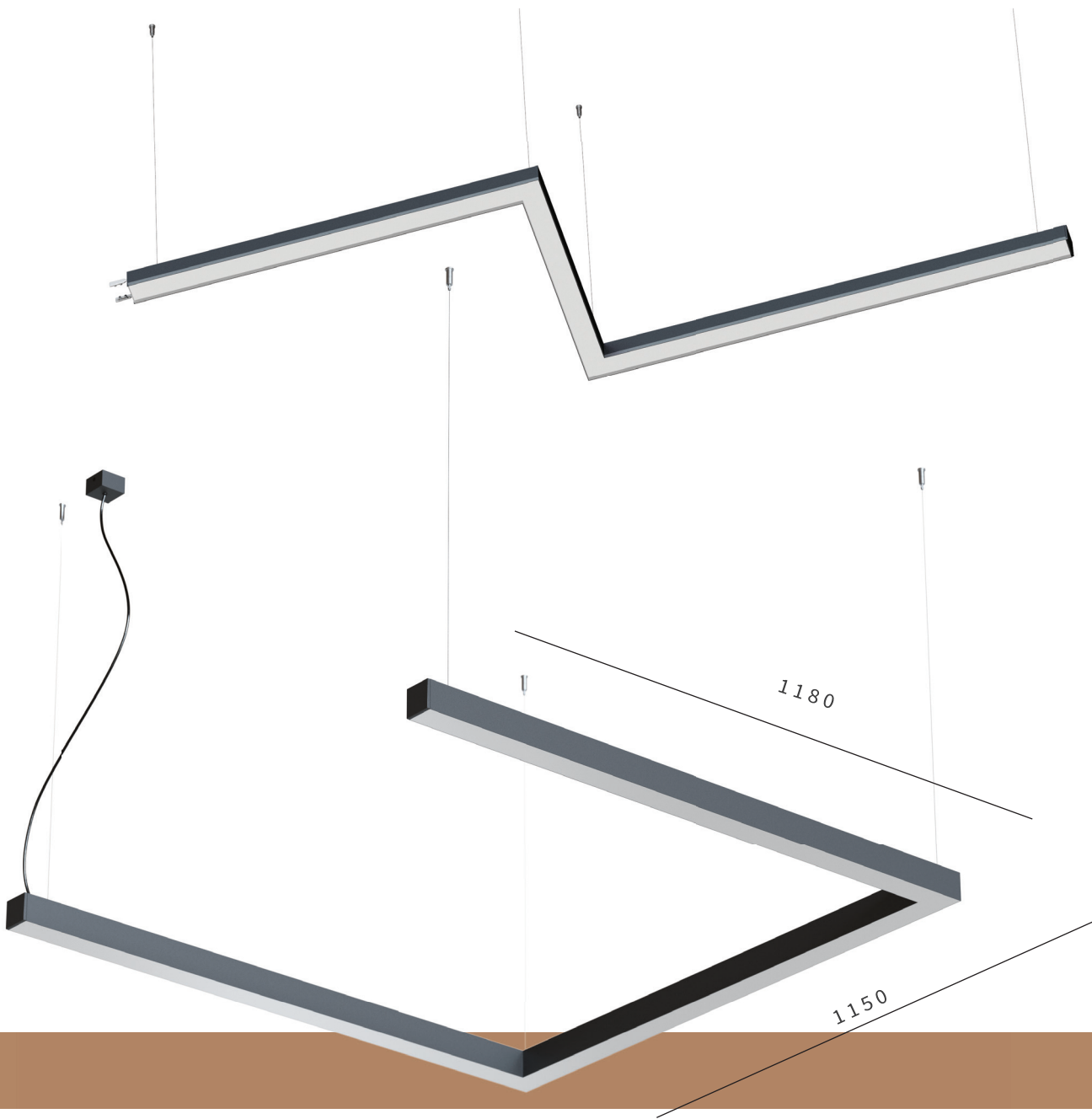

MADE IN EU
CLEONI

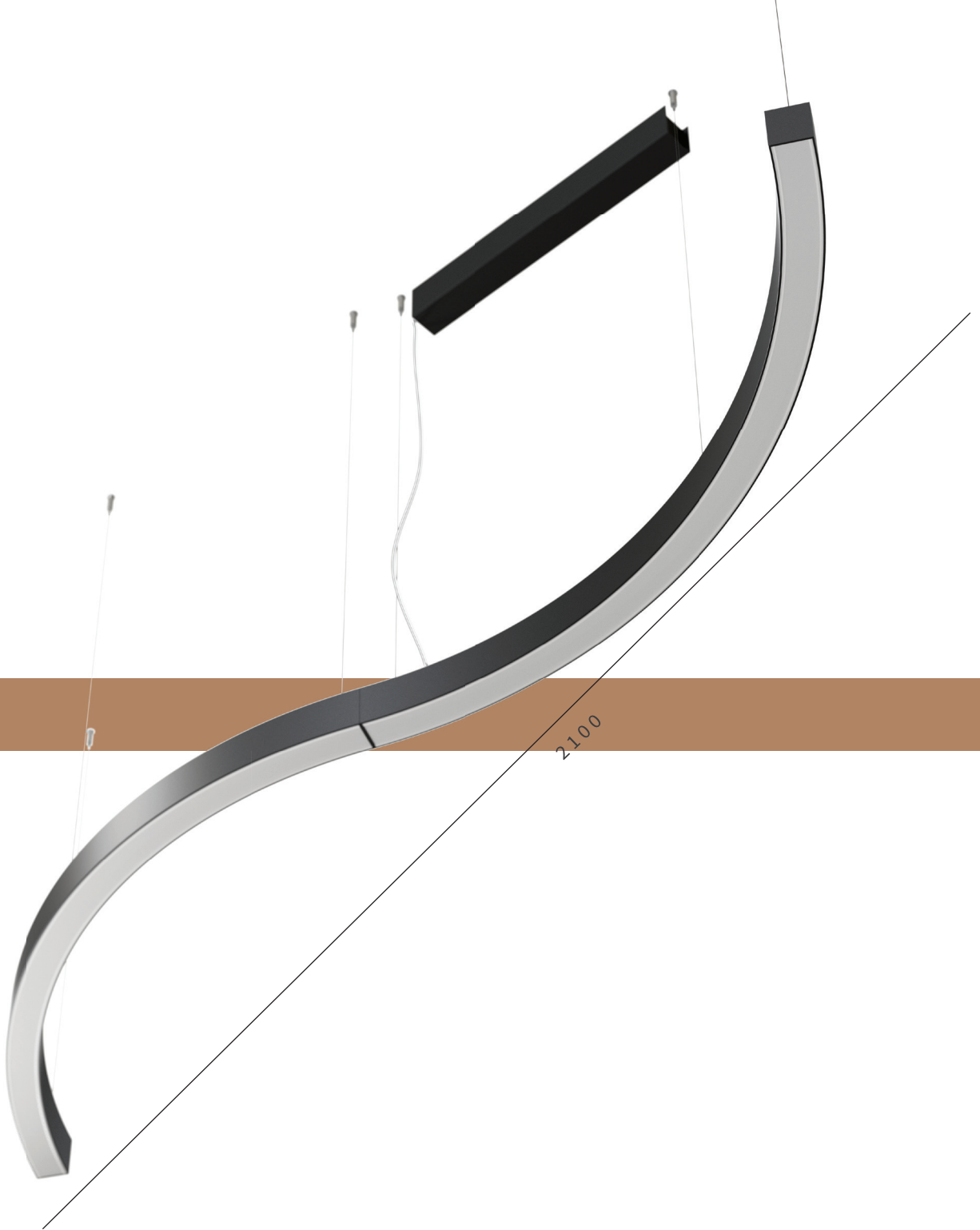

CLEOLINE - W P E N D A N T

P E N D A N T L U M I N A I R E : C L E O L I N E - W

L I G H T S O U R C E : L E D *

M A T E R I A L : A L U M I N I U M , S T E E L



* L E D P H I L I P S

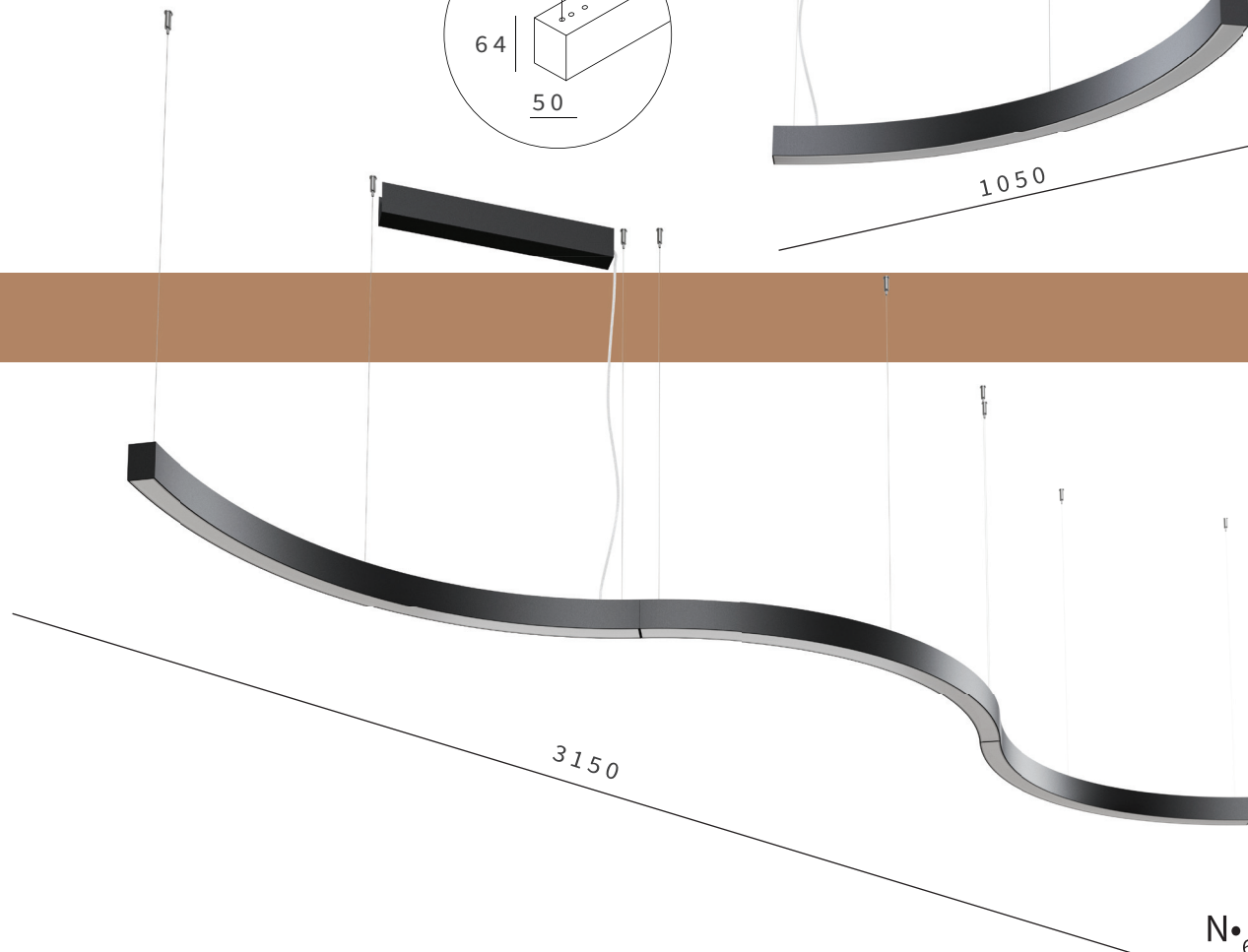
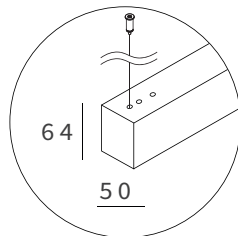

NEW

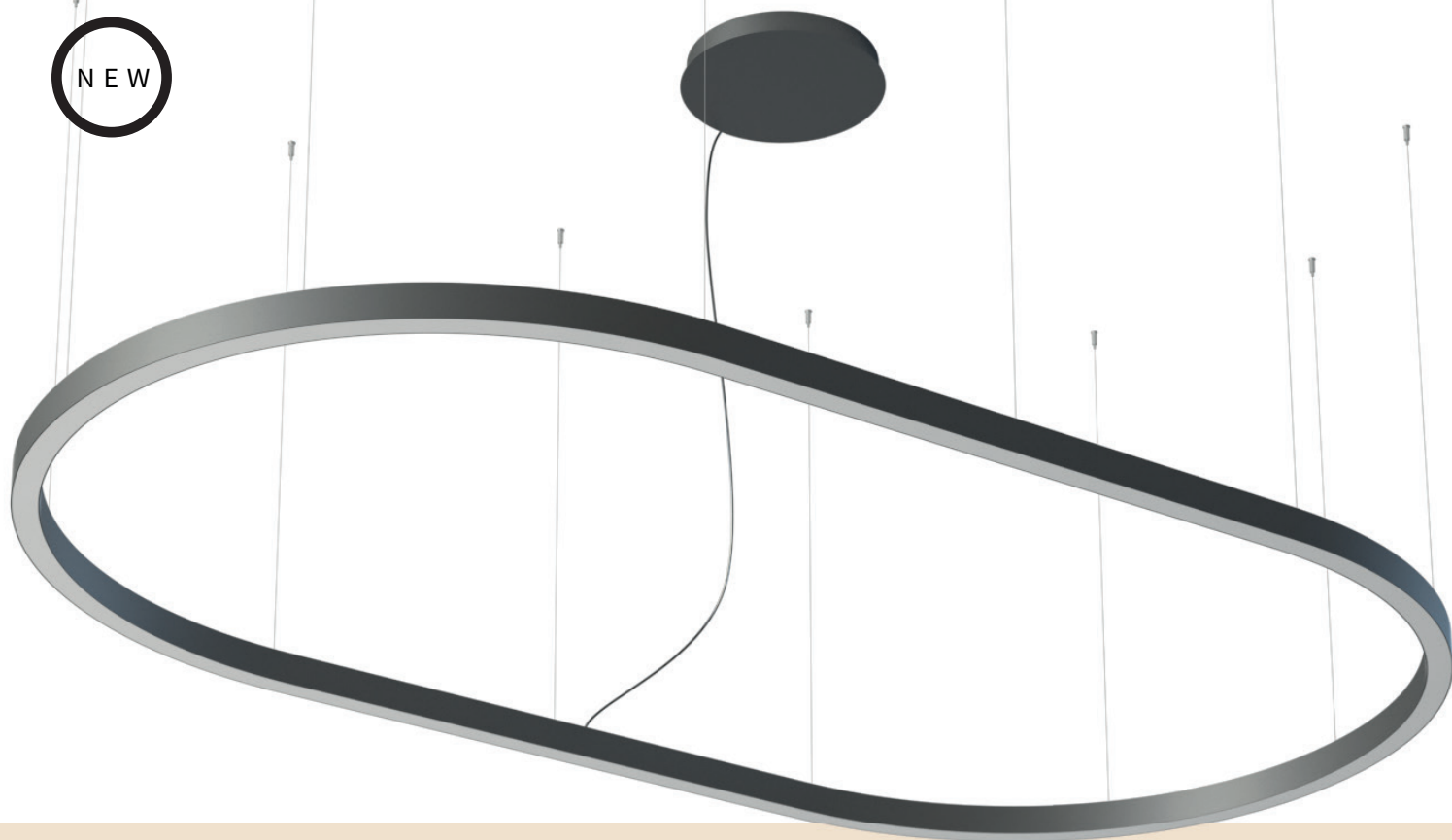

CLEOLINE ARENA PENDANT

PENDANT LUMINAIRE: CLEOLINE ARENA

LIGHT SOURCE: LED*

MATERIAL: ALUMINIUM

*LED PHILIPS



CONFERENCE ROOM,
POLAND
OOSTU I KINNARPS

PHOTO BY:
ZOFIA ŁOBZA

ALFREDO PENDANT / 1408

PENDANT LUMINAIRE: ALFREDO

LIGHT SOURCE: LED*

MATERIAL: ALUMINIUM, STEEL



*LED PHILIPS

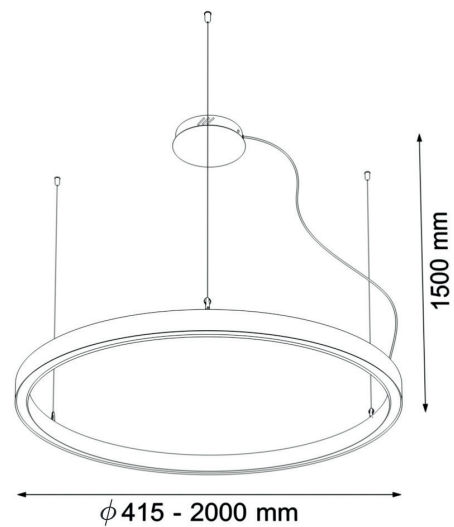

MADE IN EU
CLEONI

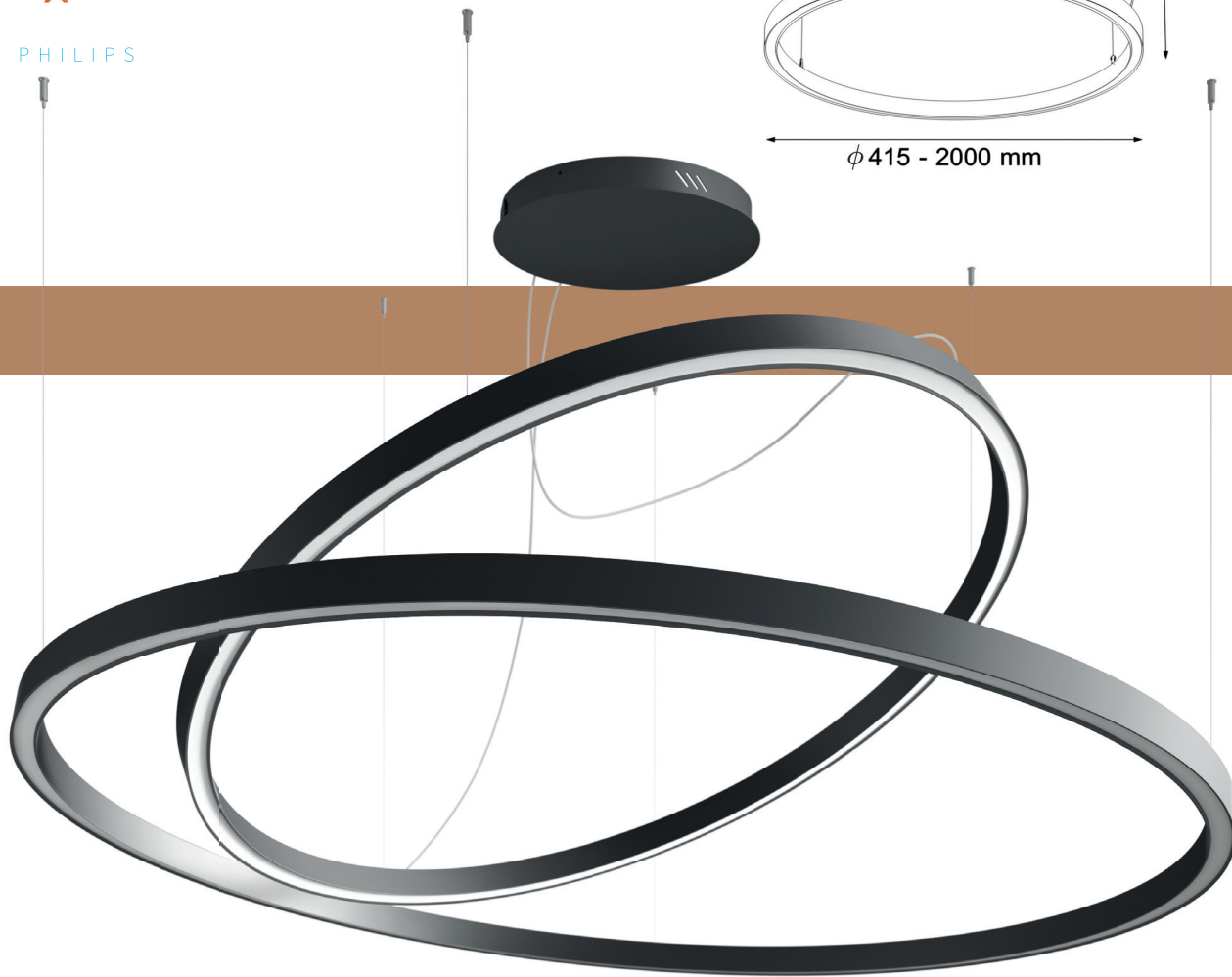



INTERIOR OF THE HOTEL CAFÉ ODPOCZNIĄ PHOTO BY: AION FILM
"RESORT I LAS" MARCIN MATYSIAK

ALFREDO CEILING / 1408

CEILING: ALFREDO

LIGHT SOURCE: LED*

MATERIAL: ALUMINIUM, STEEL



*LED PHILIPS



Ø400 - Ø2000



SHOWROOM INTERIOR
"GOLDENMARK" WARSAW





INTERIOR DESIGN BY:
DANUTA PIETROWICZ STREFA 0
PHOTOS: EWA GÓCZYŃSKA



INTERIOR DESIGN:
PIK STUDIO ARCHITEKCI



MADE IN EU
CLEONI

“DESIGNING IS NOT A PROFESSION BUT AN ATTITUDE...
THINKING IN RELATIONSHIPS.” LASZLO MOHOLY-NAGY

64

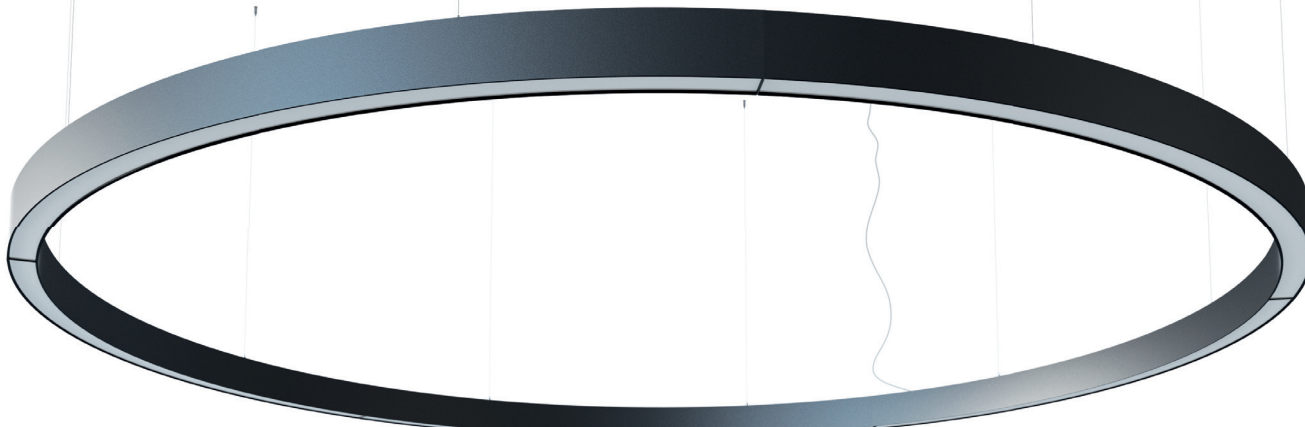

Ø2500 - Ø6000

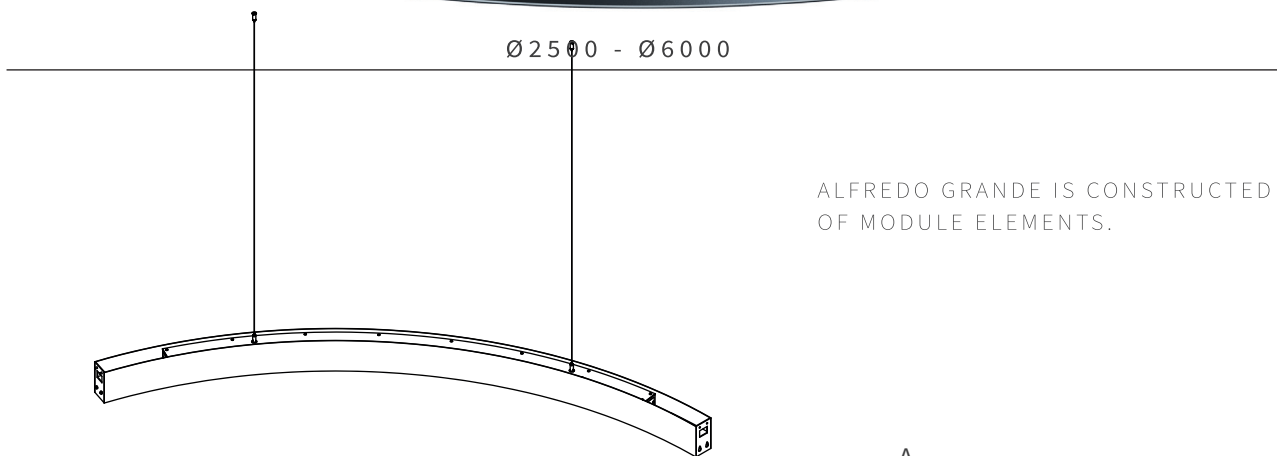

ALFREDO GRANDE IS CONSTRUCTED OF MODULE ELEMENTS.



ALFREDO GRANDE PENDANT

PENDANT LUMINAIRE: ALFREDO GRANDE

LIGHT SOURCE: LED*

MATERIAL: ALUMINIUM



*LED PHILIPS

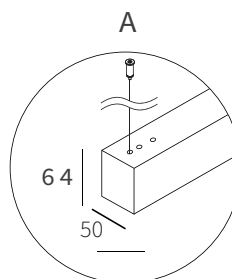

N. 75

MADE IN EU
CLEONI



„DESIGN IS THE APPLICATION OF INTENT - THE OPPOSITE OF
HAPPENSTANCE, AND AN ANTIDOTE TO ACCIDENT.” ROBERT L. PETERS

PEDRO PENDANT / DM103RA

PENDANT LUMINAIRE: PEDRO

LIGHT SOURCE: LED*, 5X PROJECTOR LED*

MATERIAL: STEEL, ALUMINIUM

 Bluetooth 

*LED PHILIPS

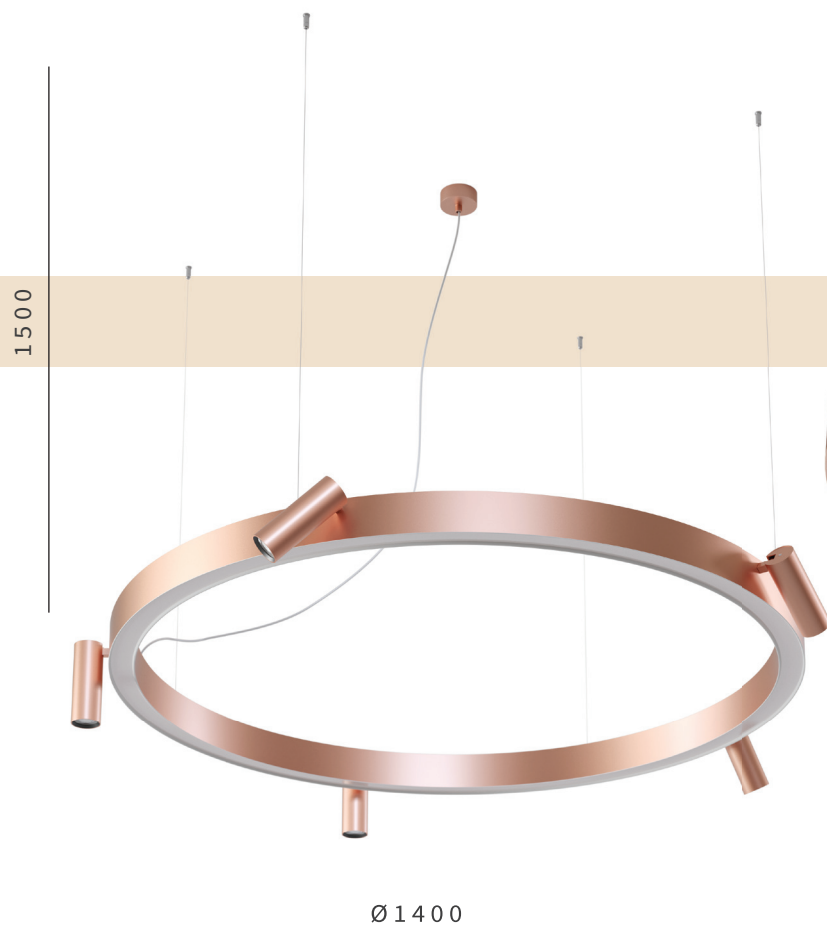

MADE IN EU
CLEONI

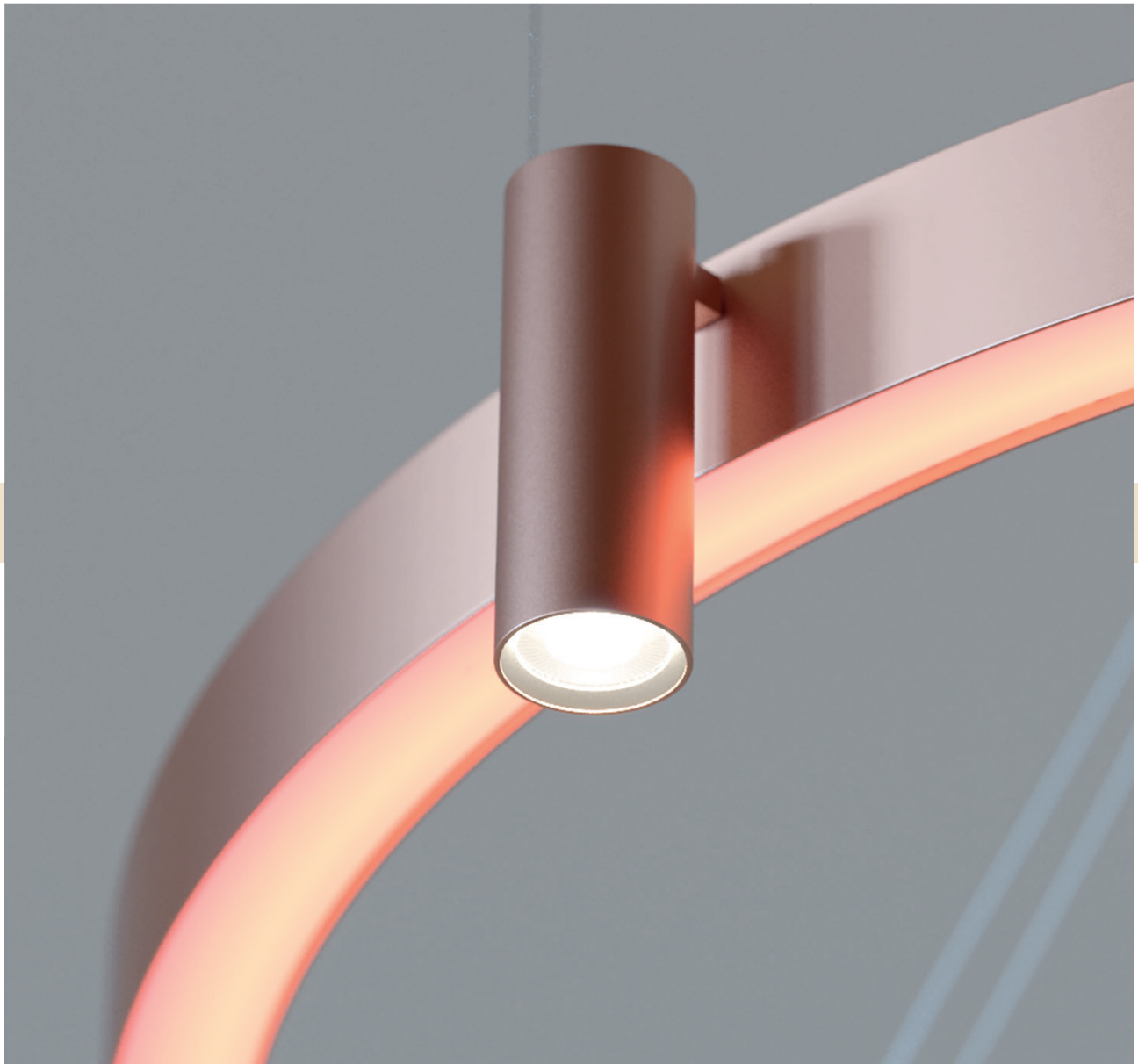

N°
78

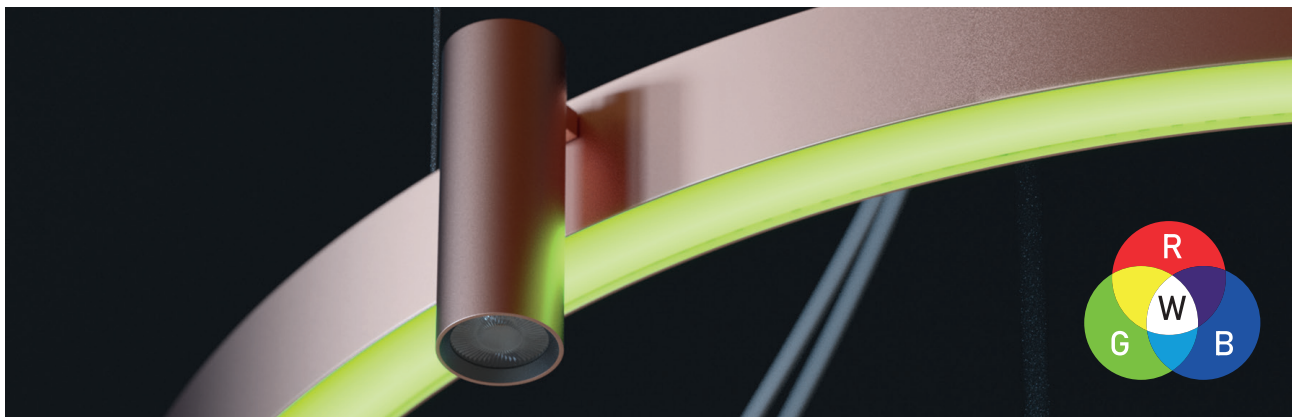
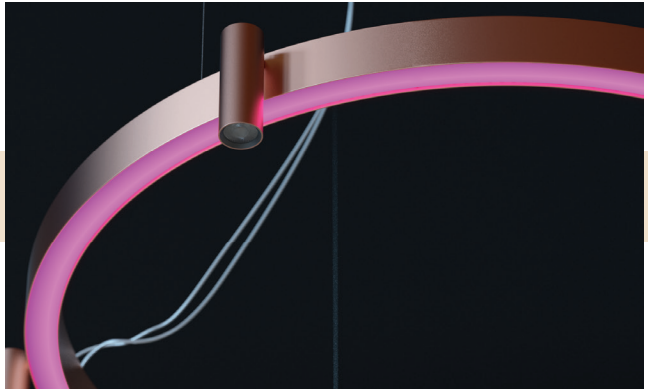
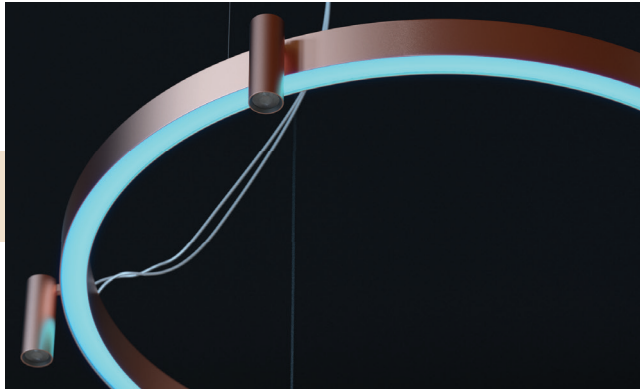
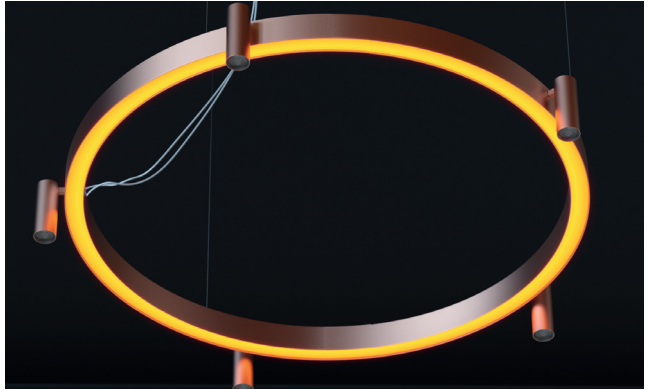
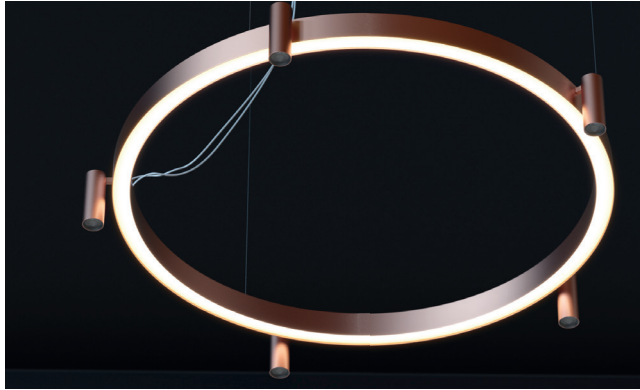

RAD PENDANT / 1394

PENDANT LUMINAIRE: RAD

LIGHT SOURCE: LED*

MATERIAL: STEEL



*LED PHILIPS



1500

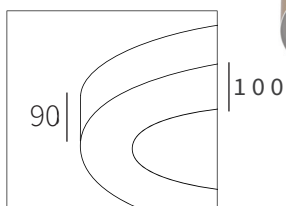
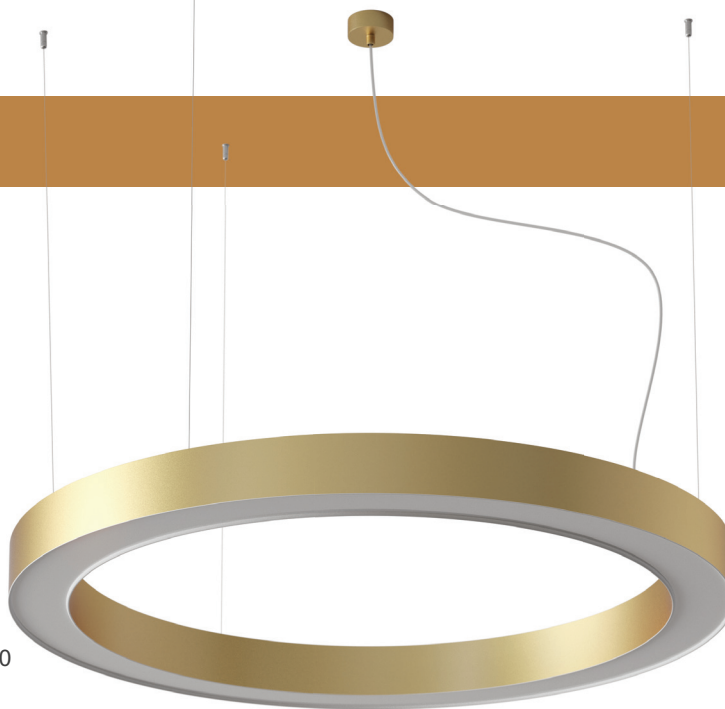

Ø800, Ø1200



PRIVATE INTERIOR : PHOTO BY:
DESIGN BY: DANUTA PIETROWICZ : EWA GÓRCZYŃSKA
STREFA D :

NEW



Ø307 - Ø1017

PENDANT LUMINAIRE: 1267/LA354/B1/Z



CEILING LUMINAIRE: 1267/LA354/A1/P



75 - 100

Ø307 - Ø1017

ABA T CEILING / PENDANT /
1267 / LA354

LUMINAIRE: ABA T
LIGHT SOURCE: LED
MATERIAL: STEEL





LUDWIG MIES „NO DESIGN IS POSSIBLE UNTIL THE MATERIALS WITH
VAN DER ROHE WHICH YOU DESIGN ARE COMPLETELY UNDERSTOOD.”

ABA PRO RECESSED/ CEILING/ PENDANT/ 1267

LUMINAIRE: ABA PRO

LIGHT SOURCE: LED

MATERIAL: STEEL

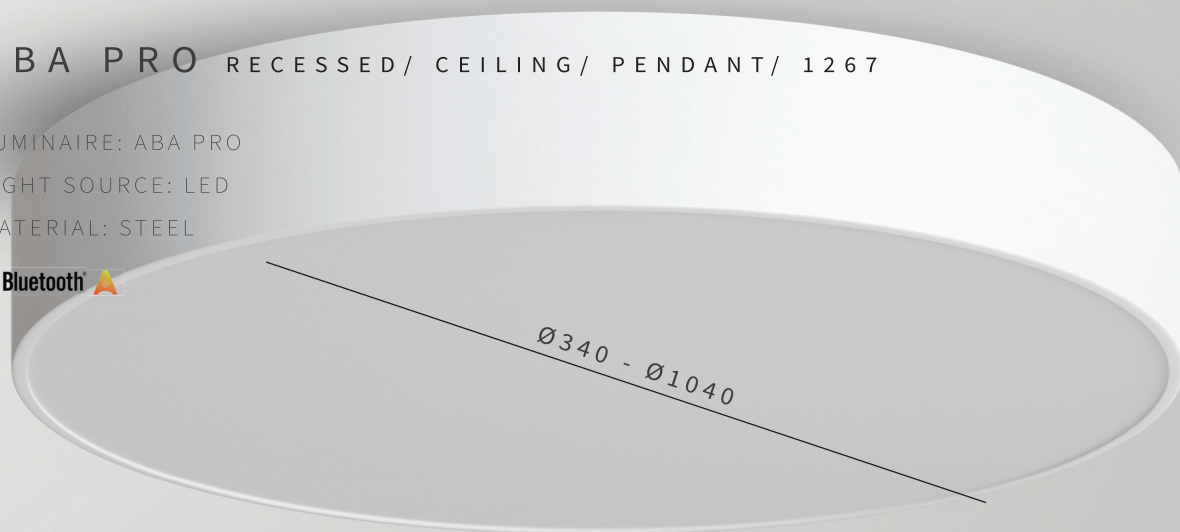
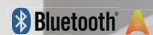

CEILING LUMINAIRE: 1267/SL05/P

PENDANT LUMINAIRE: 1267/SL05/Z



RECESSED LUMINAIRE: 1267/SL05/W

ABA PREMIUM CEILING / 1267

CEILING: ABA PREMIUM

LIGHT SOURCE: LED*

MATERIAL: STEEL



*LED PHILIPS

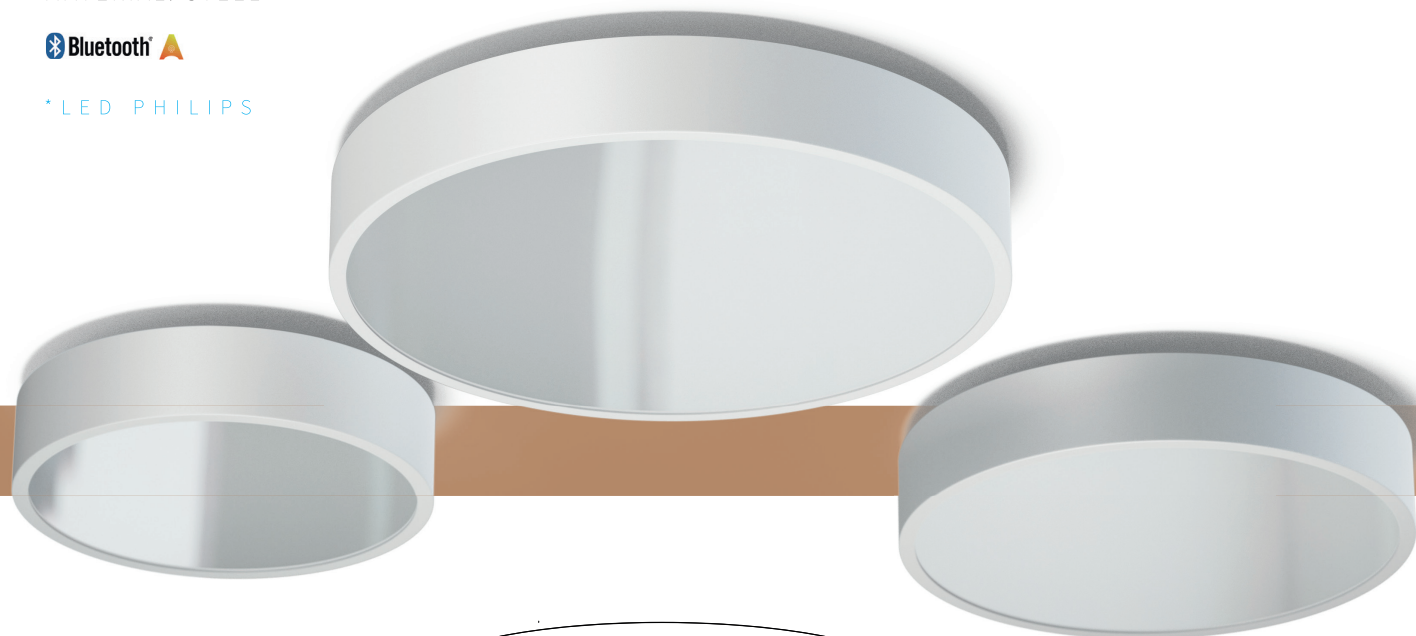

MADE IN EU
CLEONI

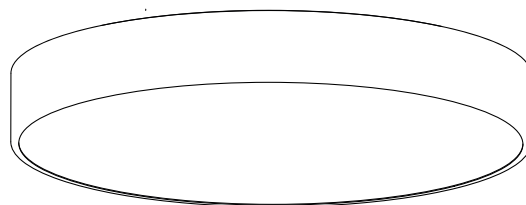

Ø 600 - 1600

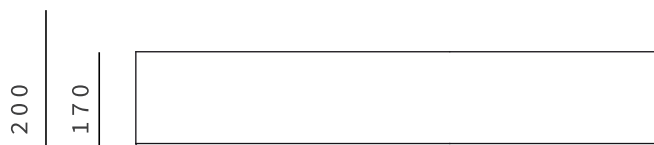

200

170

Ø 600 - Ø 1600

NER PENDANT/T169

PENDANT LUMINAIRE: NER

LIGHT SOURCE: G9 LED

MATERIAL: STEEL



N•₈₆



1500



Ø300 - Ø600



NER PANEL-CLEONI WARSAW HOME EXHIBITION STAND



HAIRDRESSING SALON INTERIOR "FEDORYSZYN" HAIRDRESSING SALON WROCLAW



NER PANEL-CLEONI

WARSAW HOME
EXHIBITION STAND

ROB 80 PROJECTOR TRACK/ TSL43

PROJECTOR TRACK: ROB 80

LIGHT SOURCE: LED* SLM

MATERIAL: ALUMINIUM

*LED PHILIPS

VERSION TL

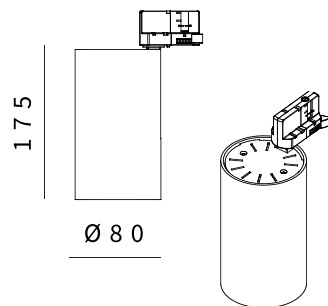

VERSION HF

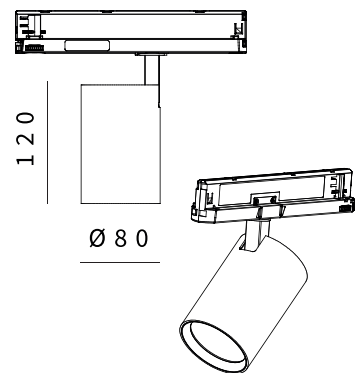



INTERIOR DESIGN
MGR INŻ. ARCH.
MAGDALENA KOPCZYŃSKA

TENNIS STORE

ANN LED SLM - MINI
PROJECTOR PENDANT / T214/LA96A1

PENDANT PROJECTOR: ANN LED SLM

LIGHT SOURCE: LED* SLM

MATERIAL: ALUMINIUM



*LED PHILIPS



N•₉₂



ANN LED SLM

CEILING PROJECTOR / T214/KL

CEILING PROJECTOR: ANN LED SLM

LIGHT SOURCE: LED* SLM

MATERIAL: ALUMINIUM



*LED PHILIPS



MADE IN EU
CLEONI



ANN LED SLM - MINI

PROJECTOR TRACK/ T214/

LA237

PROJECTOR TRACK: ANN LED SLM

LIGHT SOURCE: LED* SLM

MATERIAL: ALUMINIUM



*LED PHILIPS

ANN LED SLM

PROJECTOR TRACK/ T214/FH

MADE IN EU

CLEONI



N•₉₄



INTERIOR DESIGN
MGR INŻ. ARCH.
MAGDALENA KOPCZYŃSKA

KANCELARIA
NOTARIALNA
POLAND, OBORNIKI WLKP

N. 95

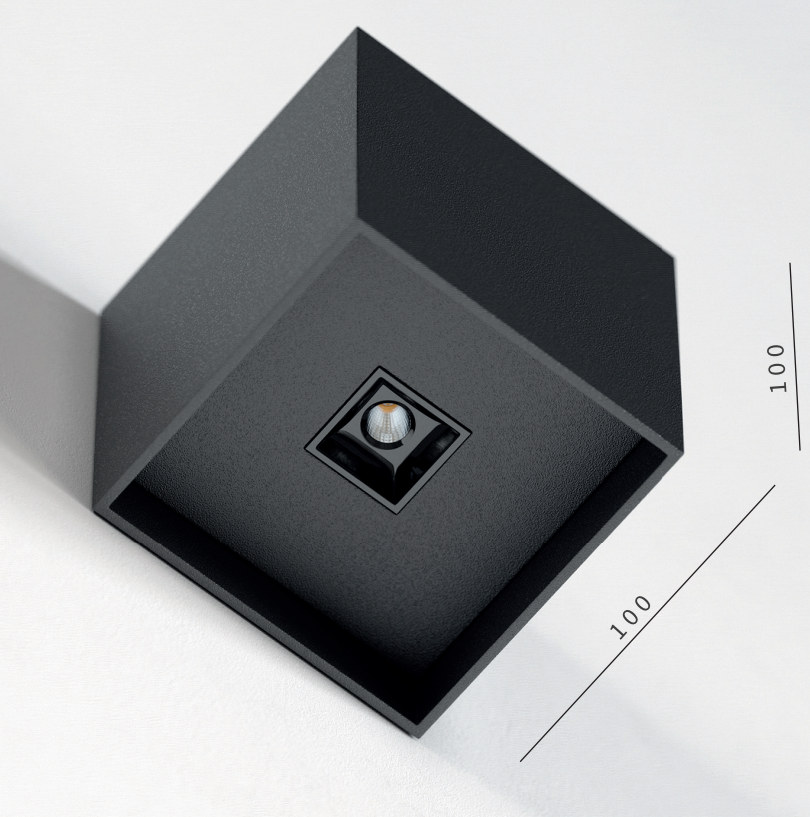

CUBO WALL LIGHT/ TLA32

WALL LIGHT: CUBO
LIGHT SOURCE: LED
MATERIAL: ALUMINIUM





MADE IN EU
CLEONI

„DESIGN IS A CONSTANT CHALLENGE TO BALANCE COMFORT
DONNA KARAN WITH LUXE, THE PRACTICAL WITH THE DESIRABLE.”

MADE IN EU
CLEONI



ASTOR LED SLM PENDANT TRACK/ T117

PENDANT TRACK: ASTOR LED SLM

LIGHT SOURCE: LED* SLM

MATERIAL: ALUMINIUM

 **Bluetooth** 

*LED PHILIPS

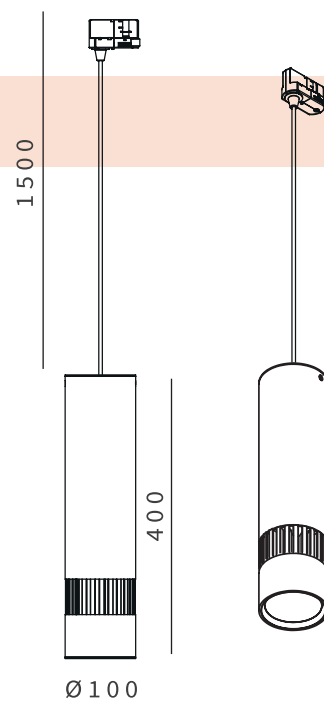

ASTOR LED SLM TRACK/ T117

TRACK LUMINAIRE: ASTOR LED SLM TRACK

LIGHT SOURCE: LED* SLM

MATERIAL: ALUMINIUM



*LED PHILIPS

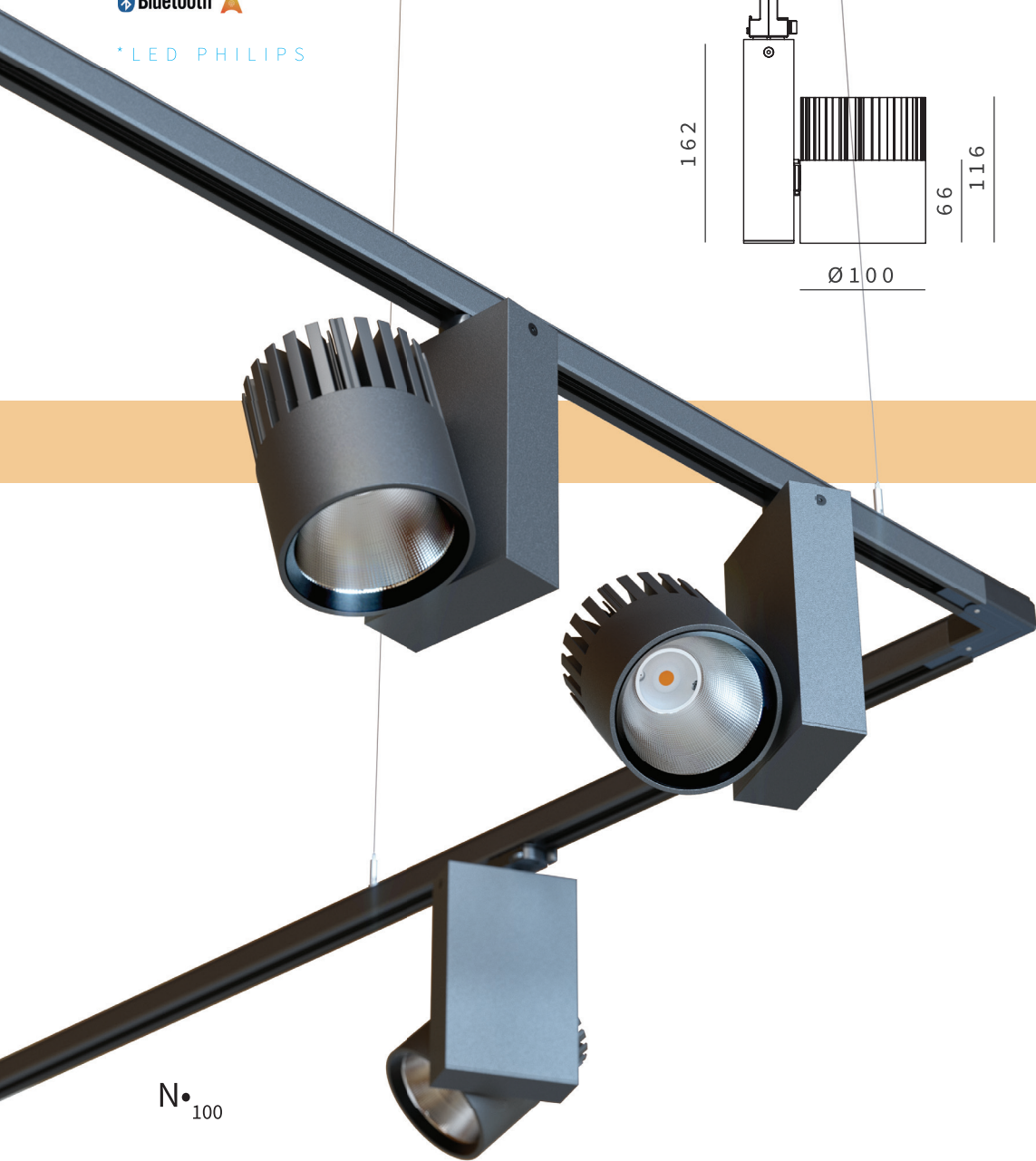
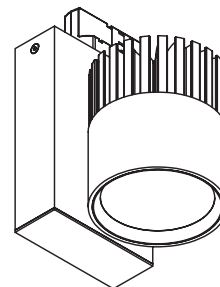
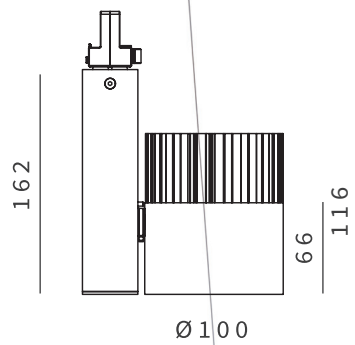

N•
100



MADE IN EU
CLEONI

THOMAS J. WATSON

„DESIGN MUST REFLECT THE PRACTICAL AND AESTHETIC IN
BUSINESS BUT ABOVE ALL... GOOD DESIGN MUST
PRIMARILY SERVE PEOPLE.“

MADE IN EU
CLEONI



„SO, TO REALLY EXECUTE DESIGN IN ITS HIGHEST FORM AND
GENEVIEVE GORDER MAKING PEOPLE FEEL JOY, THAT'S A GREAT REWARD.”

ASTOR LED SLM PROJECTOR CEILING/ T117

PROJECTOR CEILING: ASTOR LED SLM

LIGHT SOURCE: LED* SLM

MATERIAL: ALUMINIUM



*LED PHILIPS

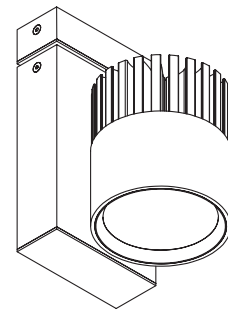
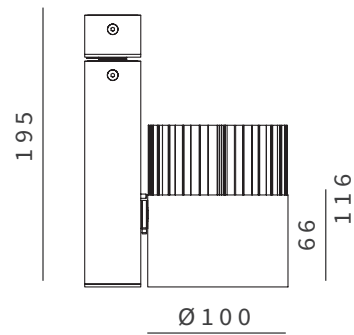



MADE IN EU
CLEONI



DENON RECESSED/ T191RT

RECESSED: DENON
LIGHT SOURCE: LED
MATERIAL: STEEL

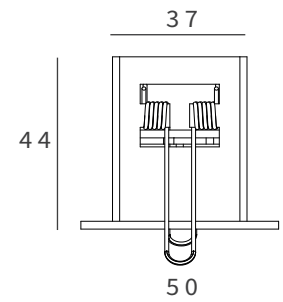

KAPS CEILING / LA359/A1

CEILING: KAPS

LIGHT SOURCE: LED

MATERIAL: ALUMINIUM

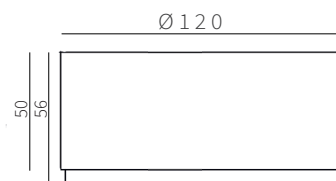
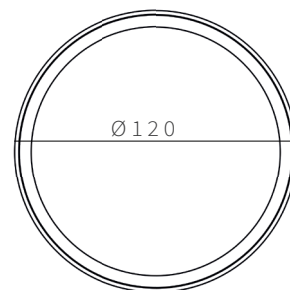

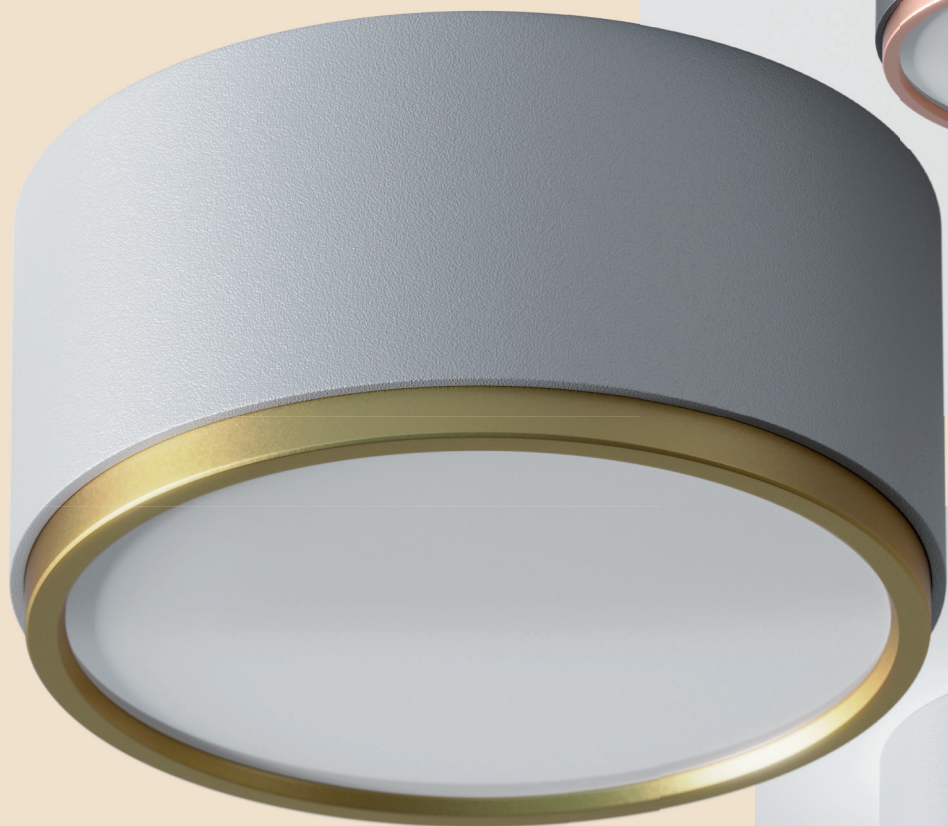

MADE IN EU
CLEONI



MADE IN EU
CLEONI

PRIVATE INTERIOR · MARINA SUCHORSKA - INTERIOR DESIGN
INTERIOR DESIGN STUDIO

ATIKA, CLIO, AMI, ENZO, INTE RECESSED

RECESSED: ATIKA, CLIO, AMI, ENZO, INTE

LIGHT SOURCE: LED* SLM

MATERIAL: ALUMINIUM

*LED PHILIPS

ATIKA-LED, LED SLM



CLIO-LED SLM

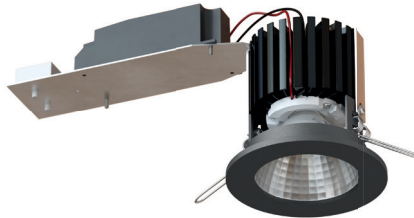

INTE-LED SLM

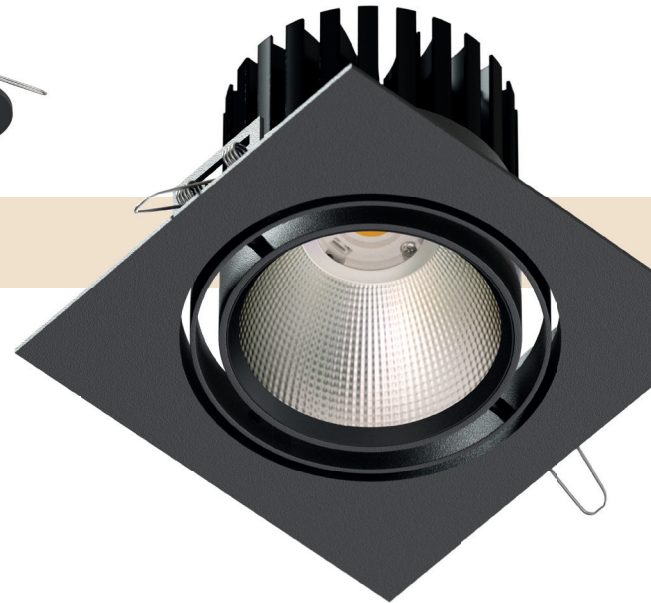

ENZO-LED, LED SLM



AMI-LED



Dziękujemy za zainteresowanie naszymi produktami.

Światło zmienia przestrzeń - a my wiemy, jak sprawić, by zmieniała ją na lepsze.

Zapraszamy do kontaktu - pomożemy dobrać oświetlenie idealnie dopasowane do Państwa potrzeb.

Cleoni

Thank you for your interest in our products.
Light transforms spaces - and we know how to make that transformation for the better.

We invite you to get in touch - we'll help you choose lighting perfectly suited to your needs.

Cleoni

CLEONI

UL. USŁUGOWA 19
64-600 ROZNOWO

WWW.CLEONI.PL

